

# ultraframe

Transforming light and space



**Classic**roof  
by ultraframe

Installation Guide  
Version 11 | MAY 2014

# Welcome



Dear Customer,

Thank you for choosing the Ultraframe Classic system. This guide is designed to make fitting simpler.

Before you commence installation of the roof, please;

- 1) Take a moment to read these two introductory pages before reading the rest of this guide.
- 2) Do not fix the frames down at this stage – only temporarily ‘pin’ the frames to the house wall( one fixing each side) to allow the conservatory to ‘float’.

Ultraframe is rightly proud of its Classic roof. Over 1½ million have been successfully installed over a 25 year period. We have continued to invest to improve the features that the homeowner will appreciate and that should make your life easier. Any feedback –positive or negative – is welcomed so we can make the Classic roof even better.

Any feedback - positive or negative - is welcomed so we can make the Classic roof even better. Please contact the Tech Support Team on 0843 208 6953 or email [techsupport@ultraframe.co.uk](mailto:techsupport@ultraframe.co.uk)



## CONTENTS

The core of the guide shows how to install a typical Georgian with Jack Rafters and glazed with glass.

<b>section 1</b>	Pre-installation checks	4
<b>section 2</b>	Roof vent sash	5
<b>section 3</b>	Main assemblies - overview	6-7
	Radius end - overview	8-9
<b>section 4</b>	Georgian roof installation	10-218
<b>section 5</b>	Clicklock removal sequence	19
<b>section 6</b>	Tie bars	20
<b>section 7</b>	Box gutter installation	21-24
	Box gutter jointing	22
	Box gutter support	23
	Box gutter raised back	24
<b>section 8</b>	Valleys	25
<b>section 9</b>	Half ridge installation	27
<b>section 10</b>	Ventilated wallplate installation	28
<b>section 11</b>	Gable installation	29-30
<b>section 12</b>	Polycarbonate support clips	31
<b>section 13</b>	Drop valley installation	32
<b>section 14</b>	Bolstered glazing bars	33
<b>section 15</b>	Muntin bar installation	34
<b>section 16</b>	TBRK	35-36
<b>section 17</b>	WOK	37
<b>section 18</b>	Lantern	38-39
<b>section 19</b>	Pagoda	40-41
<b>section 20</b>	Cornice installation	42-47
<b>section 21</b>	Super duty eaves beam	48
<b>section 22</b>	Inter-rafter	49
<b>section 23</b>	L Shape ridges	50-53
<b>section 24</b>	Conservafash	54
<b>section 25</b>	Roof vent installation	55
<b>section 26</b>	Capping removal	55

**ALL box gutters (especially those with tie bars or joints) MUST be supported.**

**Ultraframe recommends several types of support for box gutters including brick piers. See page 22 for details of our solutions. Fitting a conservatory box gutter without adequate support will lead to structural failure. Please take the correct steps BEFORE installation.**

# TOOLS REQUIRED



8, 10, 13mm  
Socket Spanner



Deadblow  
Hammer or White  
Rubber Mallet



No. 2 Pozidrive Bit



5mm Wide Flat  
Blade Screwdriver



Hack Saw



Drill/Screwdriver



Long nose pliers



Gasket Shears/  
Snips



4.5mm Drill Bit  
10mm Drill Bit



Sealant Gun



2 x 5mm Allen  
Keys (Vic fixing kit)



17mm Open  
Ended Spanner  
- Tie Bars



Spirit Level



Tape Measure



Anglefinder



Plumb bob

Eaves to frame fixings, host wall fixings and ridge top cap flashing trim screw not supplied.

## General points

Care should be taken when handling components that are seen by the homeowner, as surfaces may be scratched if not handled with care. Choose a suitable area for unpacking the components and always check them before fitting. Any claims for missing or damaged parts are only accepted in line with our standard terms and conditions of sale.

## Health & safety

Site safety is particularly important. The installation company shall be responsible for the safety of all of the fitting team, the customer and members of the public.

The Surveyor should have carried out a risk assessment to reduce risk on site and this should have been discussed with you prior to starting.

Please use safe working platforms and ladders that comply with BS EN 131. Always use equipment in line with manufacturers recommendations. Personal Protective Equipment – such as goggles, mask and ear defenders – should be used when, for example, grinding out for the flashing.

Careful consideration should be given to the safe disposal of all packaging – Ultraframe packaging is predominantly made from recycled materials and can be readily recycled.

## Product

The roof kit is supplied with a location plan, a quality control check list for the box in which this guide arrives and, of course, this installation guide. The location plan is used to match individual components to their respective position on the roof. Our numbering convention always starts at the top left, against the house wall as you look from outside the conservatory back at the host wall.

The majority of aluminium and PVCu components contain identification codes, usually by inkjetting or labelling – should you need to re-order a part this should help. Please ask for a copy of our Classic product guide to keep in the van, which will give you further assistance with future identification – please call 01200 452367 to request a copy.

## Sealing

It is important to use the correct sealant when sealing the roof.

1. For roofs glazed with Polycarbonate ( or standard sealed units) a low modulus neutral cure brand of silicone must be used
2. For roofs glazed with Conservaglass or other true `self cleaning` glass, then MS Polymer sealant such as Rotabond 2000 must be used.

## Sealed Units

All protective handling tape must be removed prior to installation. For the correct selection of sealant please see above

## The Superstructure

Check the Dwarf wall or Plinth for being level all round. Ensure that all frames which abut the host wall are vertically plumb, which will then allow perfect alignment with our Classic eavesbeam. Before starting to install the roof, please check the condition of the host wall and whether it's plumb – depending upon what you find, these conditions can seriously affect the final integrity of the roof, particularly when a Tie Bar Replacement Kit (TBRK) is fitted.

## Technical Support

Tel: 0870 414 1008

Fax: 0870 414 1018

Email: techsupport@ultraframe.co.uk

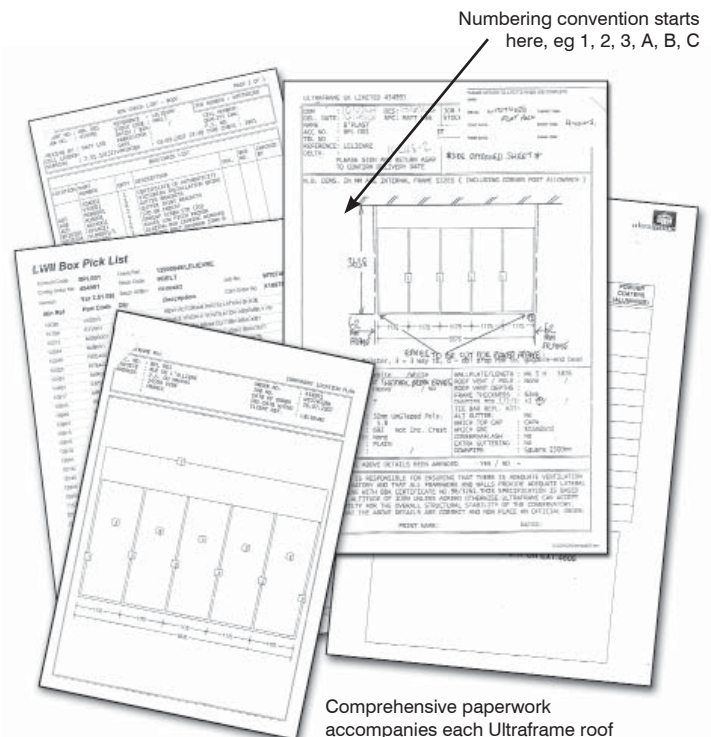

Comprehensive paperwork  
accompanies each Ultraframe roof



# Section 1

## PRE INSTALLATION CHECKS



Unpack the roof vent sash and assemble as across. If possible, do this in the factory the day before.

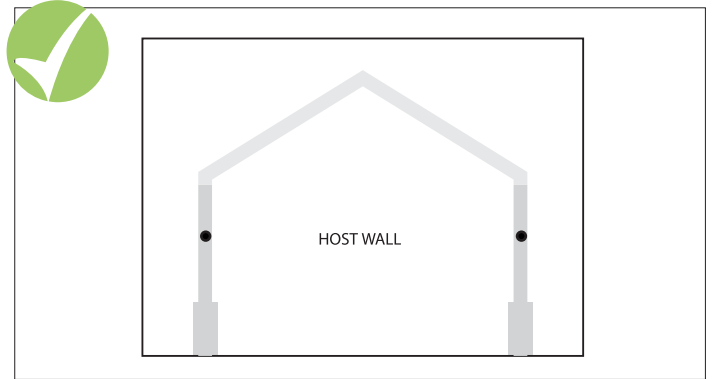

At this stage do not fix the frames down - pin only to the house wall (one fix per side) to allow the conservatory to 'float'.



Take the glazing bars from the roof pack and check the anchor clips are fitted (the clips are always at the top of the slope). On the eaves beam check that there are the correct amount of twin and single bolts and that the glazing support trim is fitted.



Attach the glazing bar end cap fixing blocks - as access restrictions (box gutter situations) may prevent easy attachment later. NOTE: These are attached to the end caps when despatched from the factory.

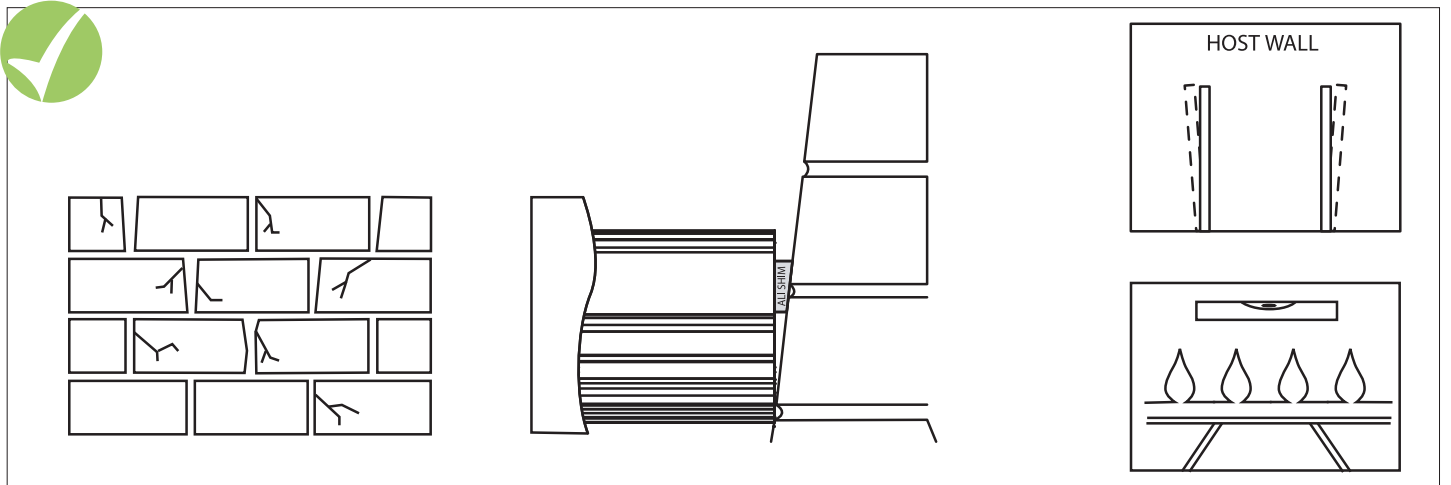

Check the condition of the host wall as this may affect the quality of the final installation. Check the host wall is plumb - any running in/or out should have been accounted for by the surveyor. If not, the ridge and starter bars may require packing out with aluminium shims. Correct alignment in this area is critical to a successful installation - Plumb frames/level ridge.

Only use the specified fixings - never be tempted to substitute alternative sizes/gauges.



**MS Polymer**

- Conservaglass
- Self cleaning glass



**Low modulus neutral cure**

- Polycarbonate glazing
- Standard sealed units

Use the correct sealant

# Section 2

## ROOF VENT SASH

**IMPORTANT:** The roof vent opening sash must be glazed prior to fitting the vent to the conservatory roof. Leaving the recommended time (dependent on outside air temperature) for the sealant to cure.

Sealant curing time will vary depending upon the time of year and outside temperature prevailing, This could take up to 8 hours in cold conditions. This is critical when the sash is to be glazed with a sealed unit.

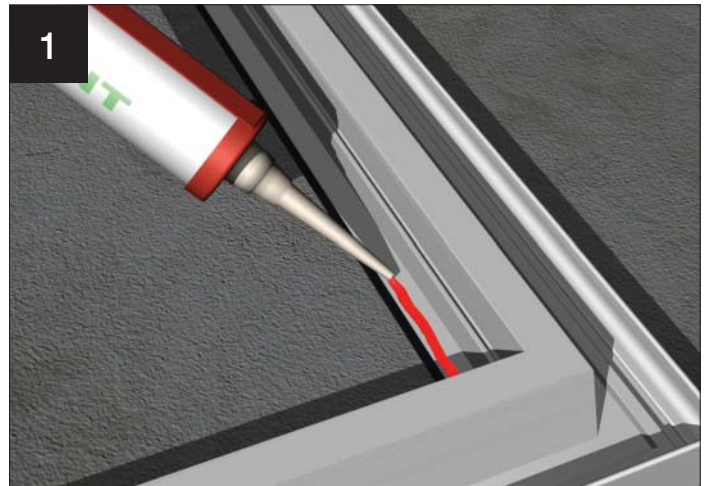

1. Remove the opening vent sash from the vent mainframe and lay the opening sash upside down on a flat surface. (Protect the surface to prevent damage to the sash). Run a continuous bead of appropriate sealant immediately behind the black co-extruded gasket, taking care to ensure a continuous run around the perimeter of the opening sash.

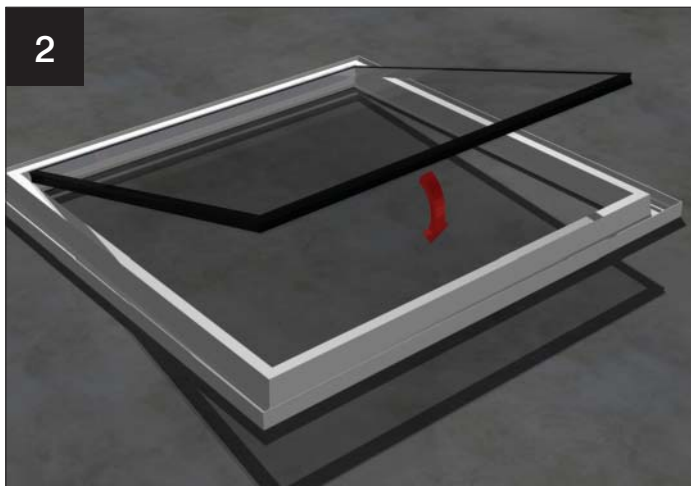

Remove all handling tape around the perimeter of the unit. When inserting the glazing ensure it is the correct way round and the external face is face down onto the continuous bead of sealant.

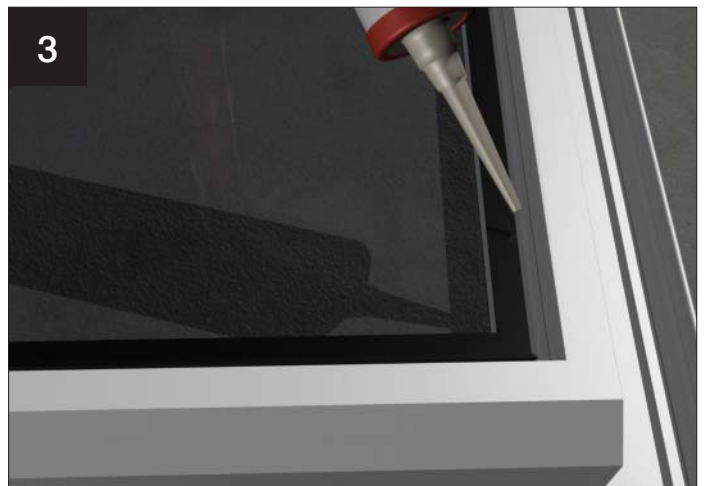

Seal the area around the perimeter of the glazing. On polycarbonate seal all sides other than the bottom breather taped edge. On sealed units seal around the full perimeter of the unit.

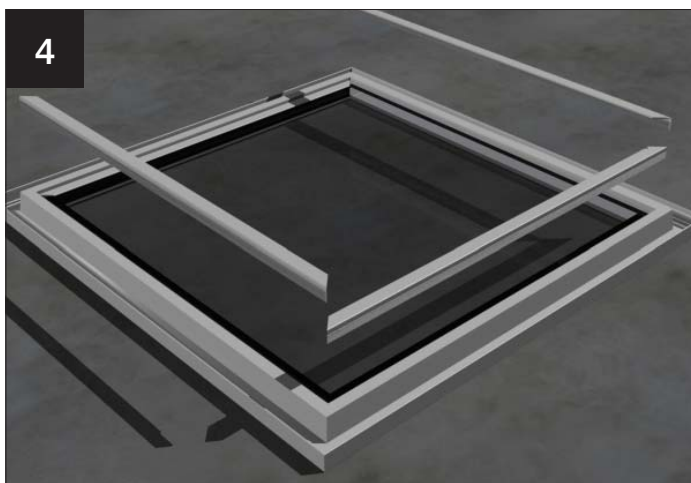

Re-fit the 'L' shaped serrated glazing beads to the opening sash. A small block of timber is useful to carefully knock in the beads.

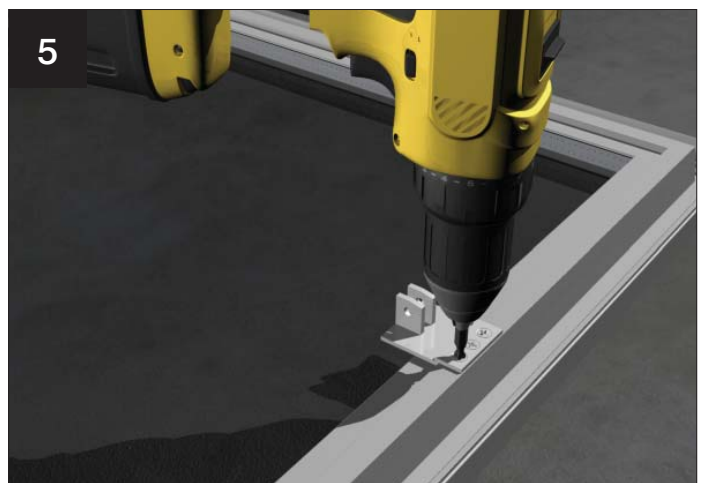

Centrally screw fix the sash bracket into the position shown above using the fixings provided. **Leave the sash to cure before fitting.**

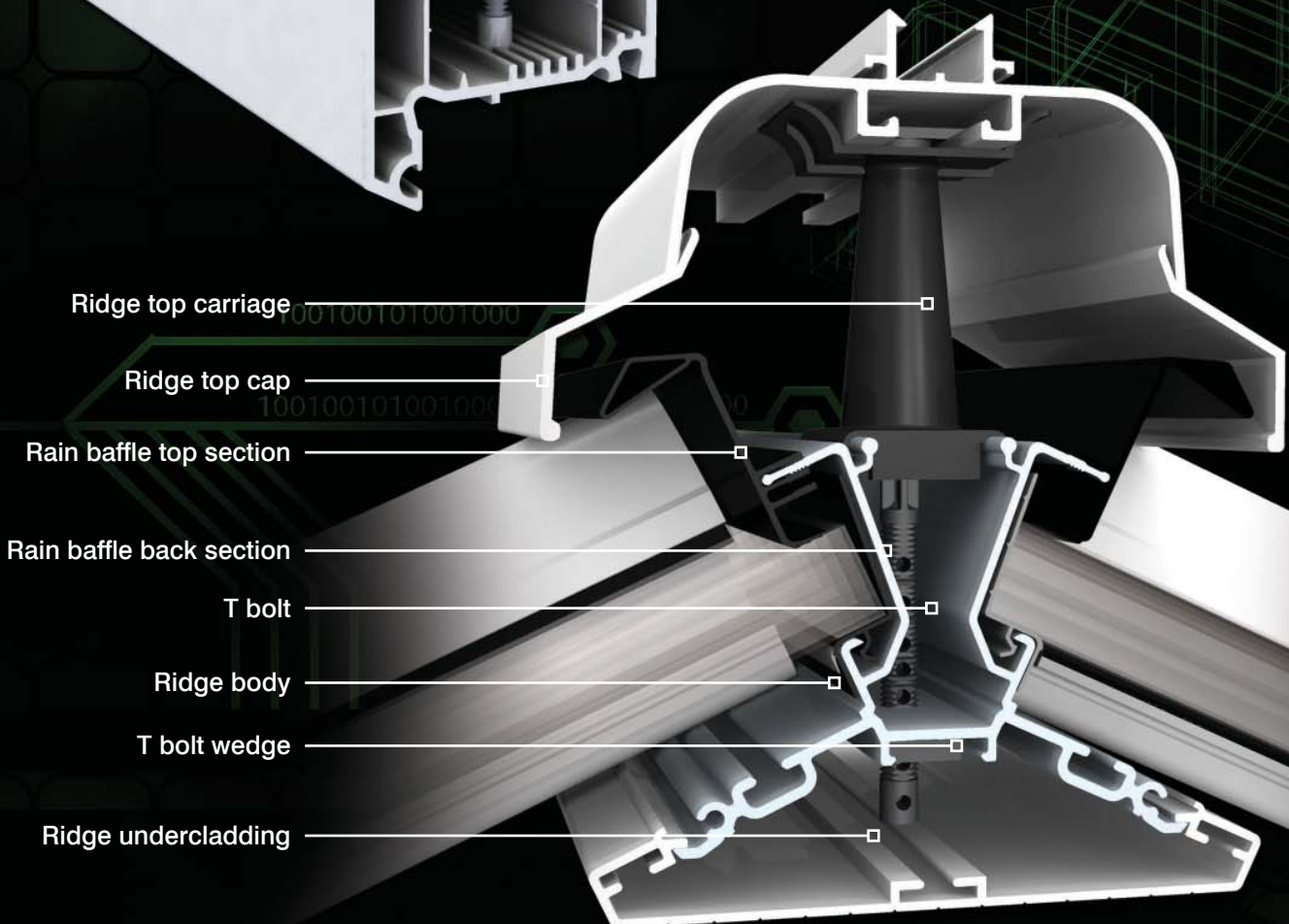



Chambered glazing bar top cappings



Standard glazing bar top cappings



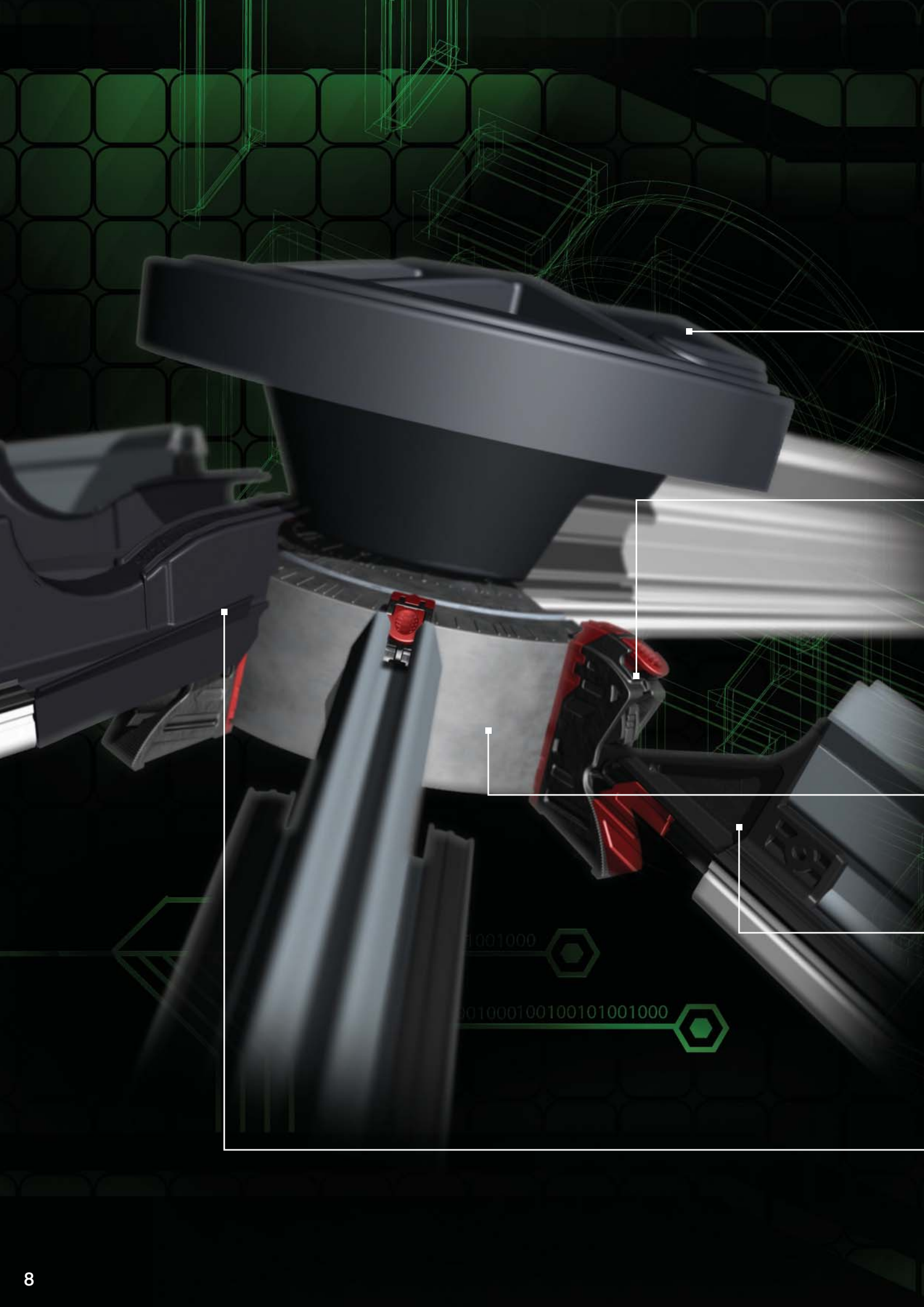



'Soft touch'  
weathering shield

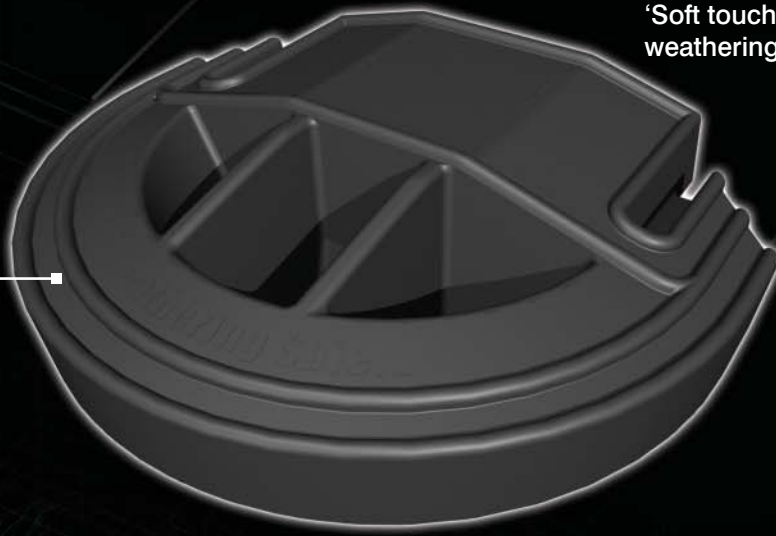

100100101001000

Speedlok 2  
socket  
assembly



Die-cast radius end



Speedlok 2 - Bar



Speedlok 2 hood



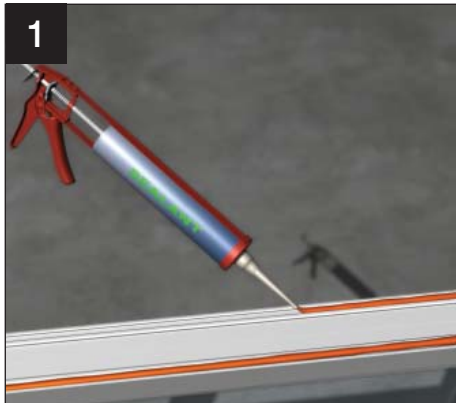

1 Apply a continuous bead of silicone to the front and rear inner legs of the window frames.



2 Fit the initial piece of eaves beam ensuring that the inside face of the eaves beam is flush with the inside face of the window frame.  
**Please note: Ensure that the under gutter trim is fitted to the eaves beam and all bolts are in situ prior to fixing to the frames.**

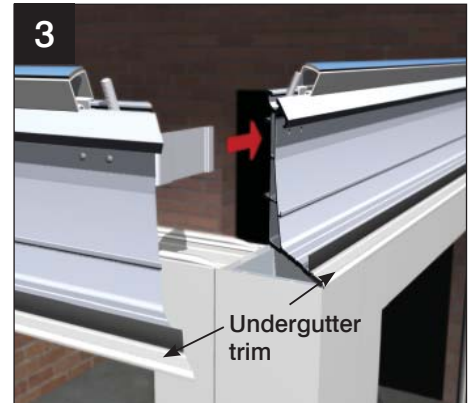

3 Place the next section of eaves beam into position, by slotting the corner cleat on the adjacent piece of eaves beam into the first piece.



4 Using the pre-drilled pilot holes, drill two 4.5mm holes through the corner cleats.



5 Securely fit the two M5 x 12mm tap screws.



6 Securely fit the eaves beam to the frames using for example, 38mm x 4.8mm screws in the position shown. Fix down at 450 centres and within 200mm of each corner. For 60mm frames use the inner eaves extrusion line and outer line for 70mm frames. Always screw down. (Not supplied)

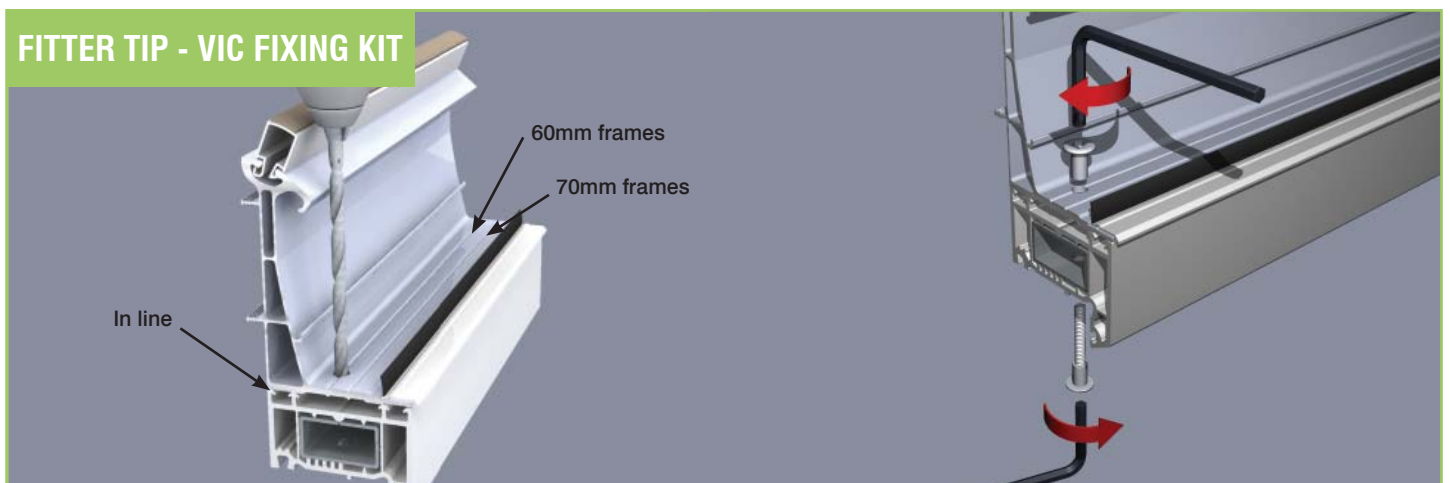

When using the Victorian Fixing Kit drill a 10mm hole through the base of the eaves beam and completely through the head of the window frame. Ensure that both sides of the 10mm hole are accessible for Allen key fixing. Use a 5mm Allen Key to tighten the fixings. The eaves beam should be fixed at 450mm centres and within 200mm of each corner. **THIS IS ULTRAFRAME'S RECOMMENDED FIXING METHOD**



## GEORGIAN INSTALLATION



Once the eaves beam is secure, run a bead of silicone down the joint where the eaves beam sections meet and where the eaves abuts the host wall. **YOU MAY AT THIS STAGE INSTALL THE GUTTERING PRIOR TO FITTING THE GLAZING BARS**



Fit the pre-formed soaker trim to each starter bar (if pre-ordered). Temporarily support the ridge and offer up the starter bars, loosely attaching using the roofing nuts and bolts supplied. **THE SOAKER ALLOWS CONSERVAFLASH OR CODE 4 LEAD TO BE DRESSED BEHIND THE STARTER BAR TOP CAPPING.**



Ensure the rain baffle upper leg is lifted prior to placing the glazing bars that fit to the ridge body sides.

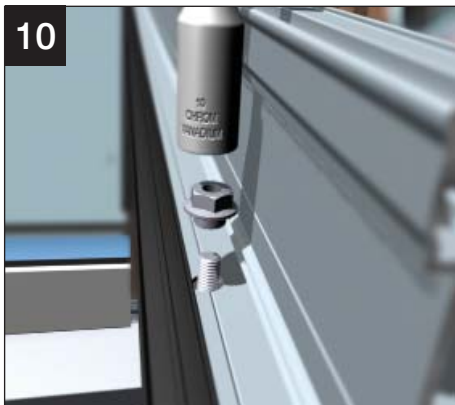

Tighten the glazing bars first at the ridge and then at the bottom (i.e. eaves beam). It will be necessary to use eaves beam packers (supplied) when the roof pitch is below 15° (lean-to) and above 35°.



Continue to support the ridge and offer up the transom glazing bars (above), loosely attaching using the roofing nuts and bolts supplied. Ensure the rain baffle upper leg (see p6) is lifted prior to placing the glazing bars.

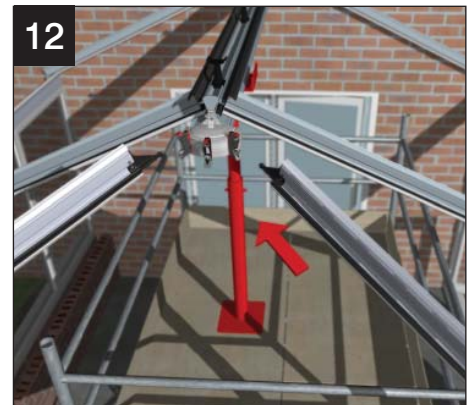

Offer up the hip bars.



Using Speedlok 2 on the glazing bar end, offer the 'ball' into the matching socket.



Attach bar at eaves position. Using your thumb push down the upper dead lock so it's flush. **YOU MUST NOT PUSH UP THE LOWER WEDGE LOCK UNTIL STEP 32.** To remove the bar, lever up the dead lock using a flat blade screwdriver, then insert the screwdriver to release the socket latch.



Next, attach the speedlok hood over each bar, sliding it under the co-extruded gasket of the glazing bar undercladding.

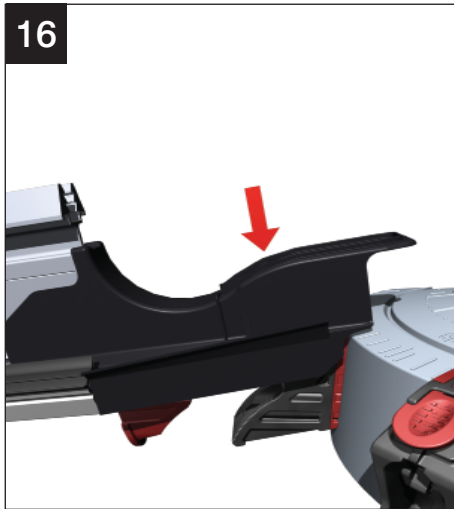

16 Push down to locate, with the final position abutting the front edge of the die cast end.



17 Continue to attach all the glazing bars using the location plan provided to check each bars final position with its corresponding label.

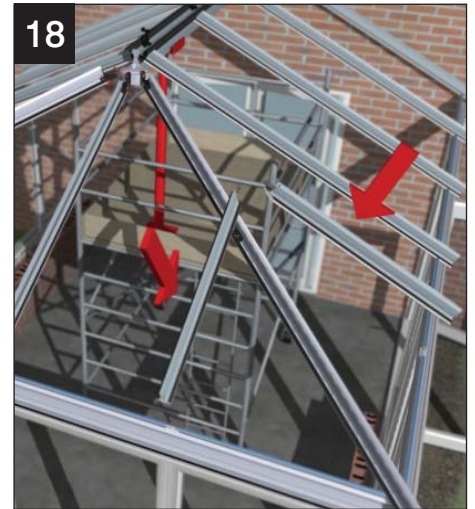

18 Now start on the jack rafters. The two part jack rafter kit will already be fitted to the hip and jack rafter bars. Again refer to the location plan and corresponding labels attached to the parts.



19 Slide back the jack rafter undercladding. Each jack rafter kit is supplied with a number of washers. Trial fit the jack rafter and check that the glazing platforms are level. Adjust if necessary by adding or removing washers between the two part connecting kit, then tighten the nut.

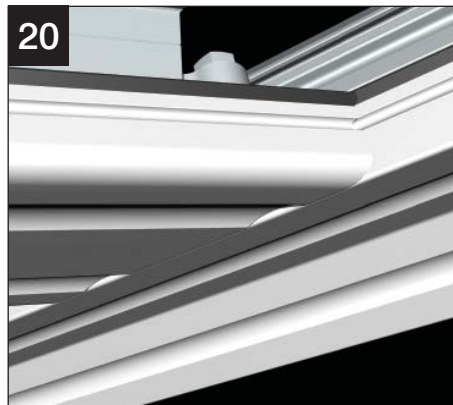

20 Slide back the glazing bar undercladding to ensure it lines through as shown above.

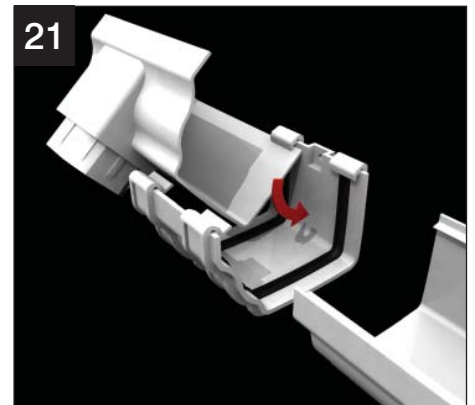

21 Next, build on the ground the gutter runs, by rolling items like a stopend under the back edge of a gutter jointer.

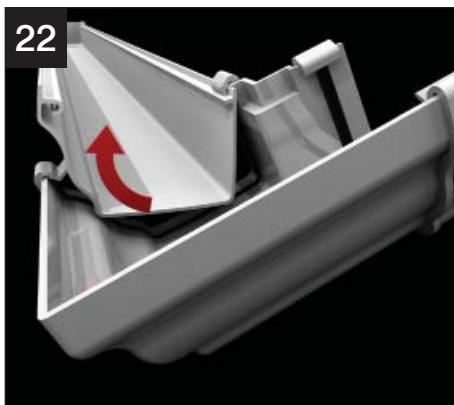

22 Snap the integral clips on the adaptors over the gutter.



23 Fit all the gutter brackets supplied with the kit at maximum 750mm centres and maximum 200mm from each corner.



24 Locate the back edge of each section of gutter into the slot in the gutter bracket.



## GEORGIAN INSTALLATION

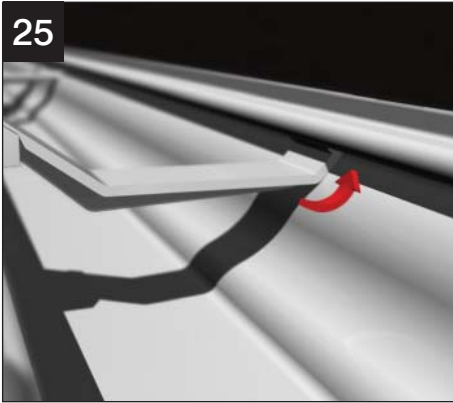

Clip the front of the bracket into the lip on the gutter. PVCu components like the gutter are easier to manipulate when warm. In cold conditions more 'force' may be required.

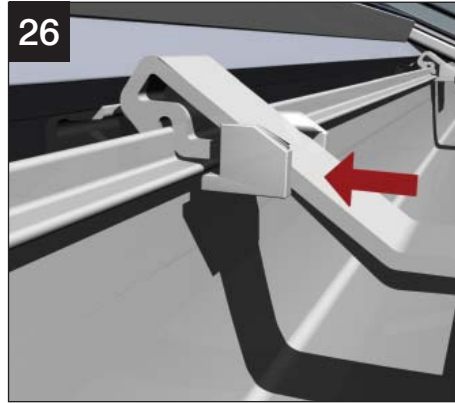

Push the sliding fixing block into place to lock out the gutter.



Ensure the window frames are plumb.



Ensure the ridge is level.



Check that the pitch of the roof is correct. Your Surveyor should have provided a drawing/a copy of the roof confirmation which displays the pitch.



Check that the starter bar and first transom bars are parallel.



Drill the starter bars/masonry within 200mm of the ridge and eaves beam plus at least one more equidistant between the two. Pack out to support the starter bar behind each fixing before fitting the correct masonry anchor. If necessary pack behind the ridge too with aluminium shims.

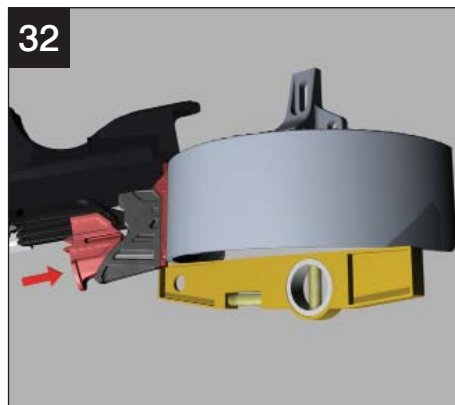

Finally when all is level and plumb, use your thumb to push up all the lower wedge locks. The roof is now set. **Now return to fasten the frames to the host wall and the dwarf wall.**



It is at this stage that pre-foamed soaker and stepped flashing are fitted

**SEE PAGE 54**



Take the 'soft touch' hub weathering shield and lift the flaps on the ridge rain baffle to insert. NOTE: If there are no side transoms in-line with the finial point, the weathering shield will need to be trimmed to suit to fit snugly over glazing.

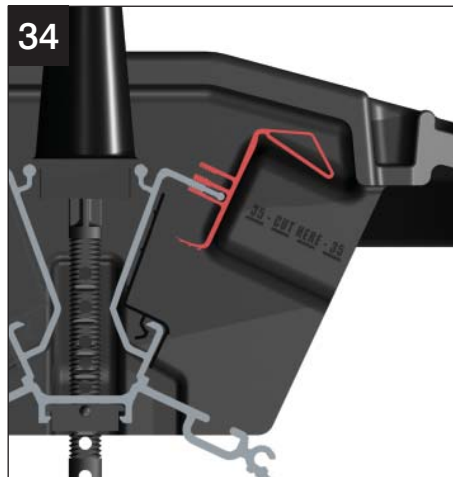

The rain baffle should nestle neatly to form a continuous weather tight joint. NOTE: CUT THROUGH THE WEATHERING SHIELD WHERE INDICATED ABOVE, IF GLAZING WITH 35MM POLYCARBONATE.



For the Georgian hip bar, 'snip' two small cuts to facilitate the Georgian top cap sliding under.

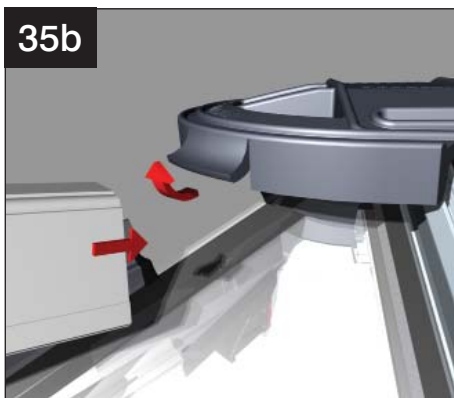

- make sure the resulting flap is pulled forward.

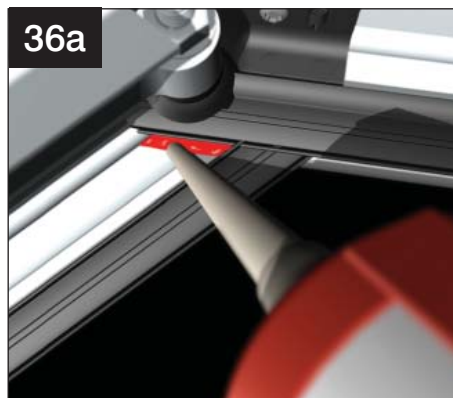

Seal the area where the co-extruded gasket on the hip bar butts against the co-extruded gasket on the jack rafter.



Now glaze the side frames before glazing the roof - this provides additional rigidity whilst working above. INSTALL TIE BARS(S) BEFORE GLAZING.

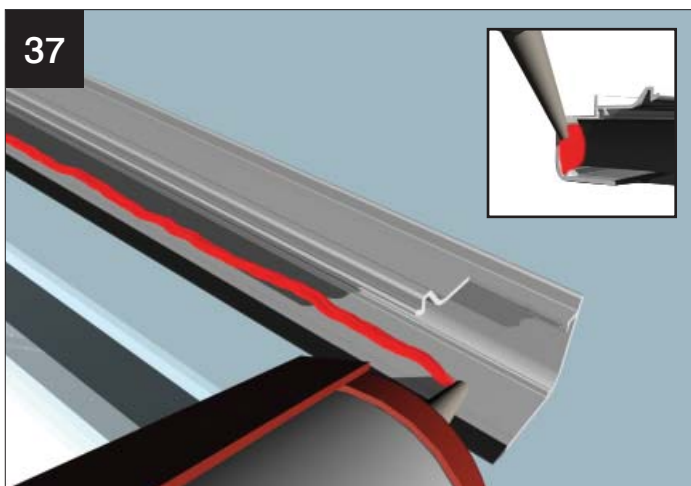

Now take the glazing end profile and run continuous bead of sealant (appropriate for glazing) immediately behind the co-extruded gasket (along the full length) and seal the space between the glazing end profile and the glazing (see inset) at each end. The glazing end profile should be provided notched for use with glass.



Snap off appropriate handed clip (left hand illustrated). Handing marked on base of clip. Line up the rounded edge on base plate next to central web of glazing bar then tuck neatly under gasket side of bar. Rotate clip into position. Push the grommet over the post as shown.



## GEORGIAN INSTALLATION



Slide the complete assembly down the glazing bar, using the endcap fixing block as the 'stop'.

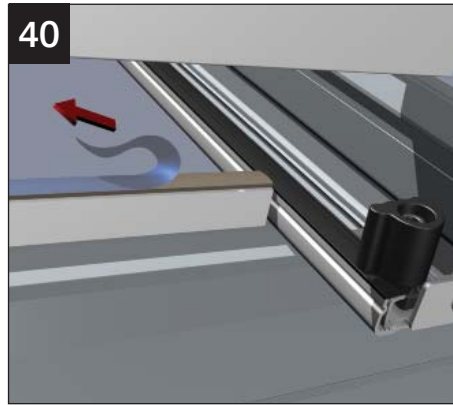

Tease the 'tail' of the glazing support trim tape free (ready to be pulled away when the sealed unit is finally in position).



Centralise the glazing between the glazing bars. If necessary pack it out on each side - press it down onto the support trim.

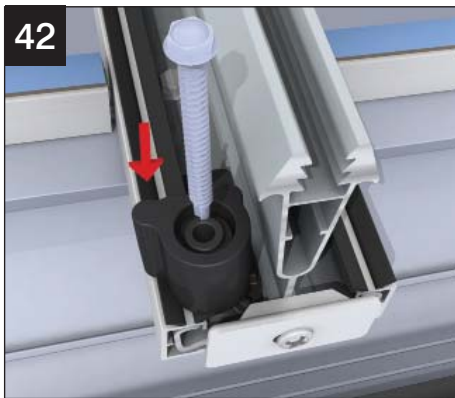

Ensure the glazing end profile sits snugly behind the grommet. Now, using the fixing provided screw down into the bar as shown.

**Ensure clip offers maximum support to glazing at all times.**

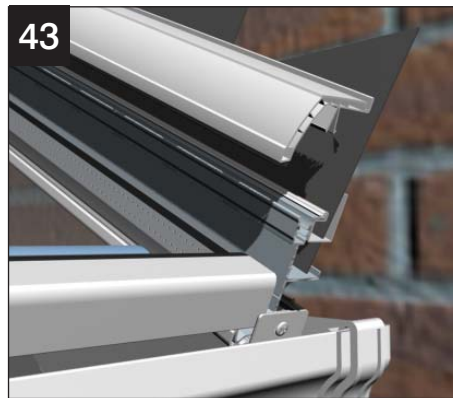

Ensure the rain baffle upper leg is lifted prior to fitting the top cappings.

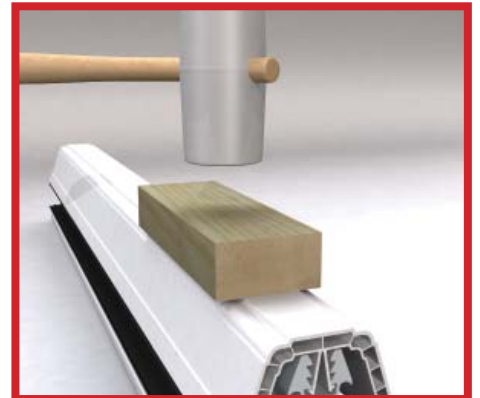

Knock the glazing bar top cappings on with a Deadblow hammer. Greater care is needed in cold weather. Keep all trims wrapped until they are needed. Once again each capping is numbered according to its position in the roof.

**If you are installing a roof vent please refer to page 55**



Work your way around the roof. The top cap must be lifted into its final resting place (at the ridge) prior to being knocked down over the Anchor clip.



Fit the glazing bar end caps by sliding onto the fixing blocks. Push fit the insert into the end cap.

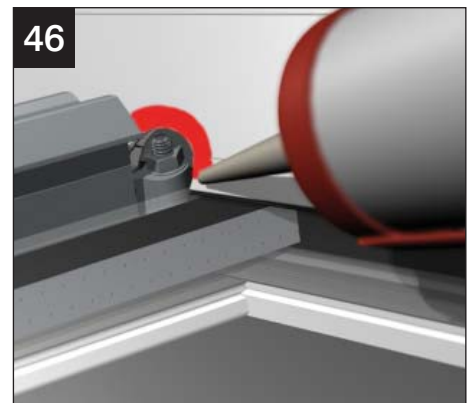

Seal around the notched Georgian top cap ready to receive the jack rafter capping.



47  
Ensure the jack rafter top capping is lined up correctly (as above) before knocking the top cappings into position. It is not possible to 'tap up' the jack rafter top caps into final position when fitted with anchor clips.



48  
The jack rafter top capping should sit tightly up to the hip bar top capping as shown.

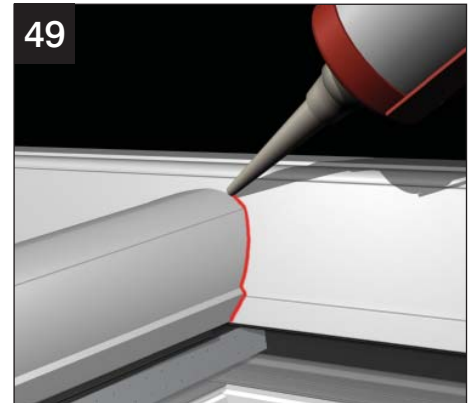

49  
Seal around the joint on the jack rafter capping when complete.

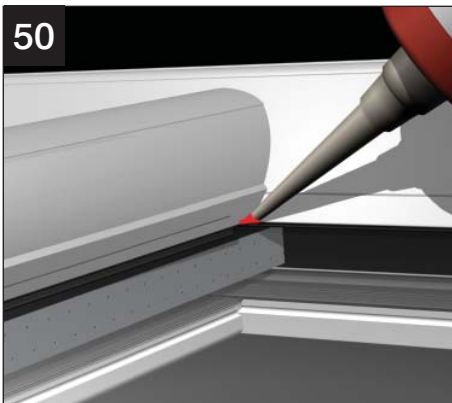

50  
Carefully point the corners on each side of the capping where the gaskets abut each other

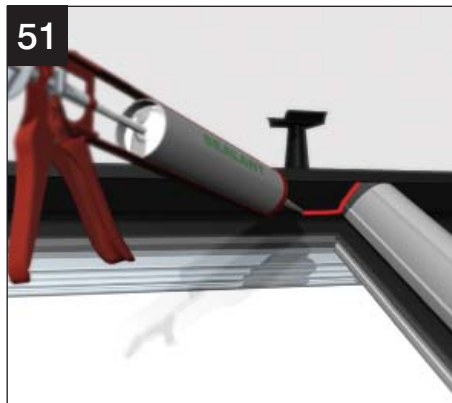

51  
Seal around the top of each glazing bar top capping where it meets the rain baffle. Next, run a bead of sealant along the edge where the glazing meets the rain baffle.

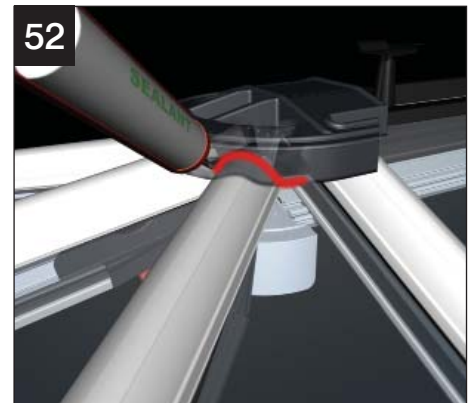

52  
Seal around each glazing bar top capping where it meets the inner wall of the 'soft touch' moulded weathering shield. Also apply a bead of sealant to the top edge of the weathering shield so that the ridge capping will seal against it when fitted.

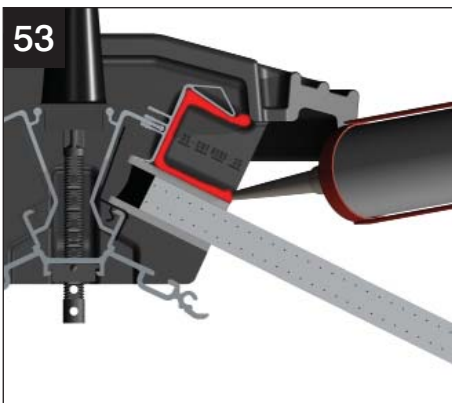

53  
Run a bead of sealant in the position shown where the 'soft touch' moulded weathering tray meets the ridge body.

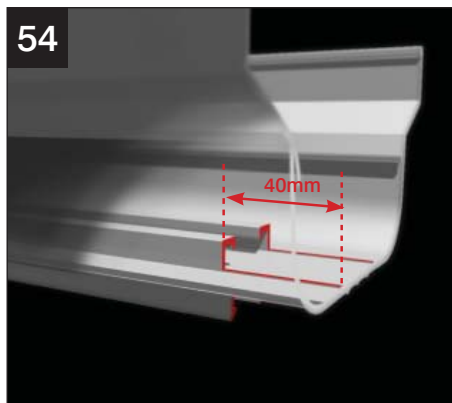

54  
Now for the ridge top cap - Cut back the cresting channel on the top and the T bolt slot on the underside of the ridge top capping by 40mm.

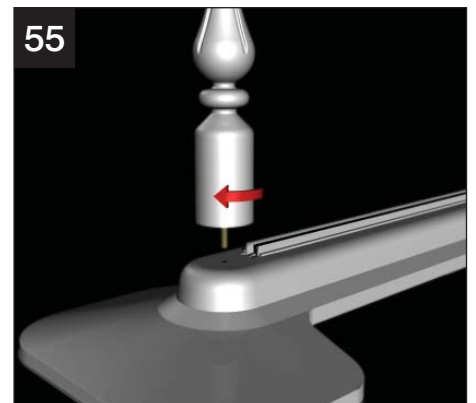

55  
Now down on the ground take the ridge top cap assembly and screw the finial into the radius end capping.



## GEORGIAN INSTALLATION

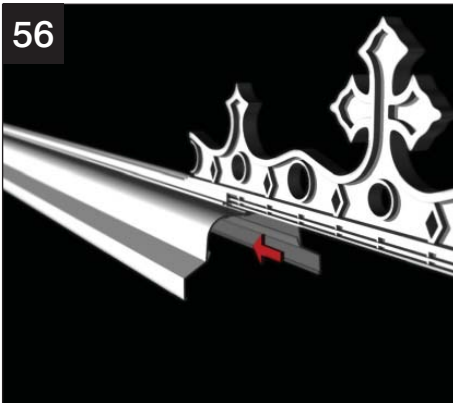

56 Slide the crestring into the ridge channel. The last section of crestring (by the house wall) may require cutting to length.

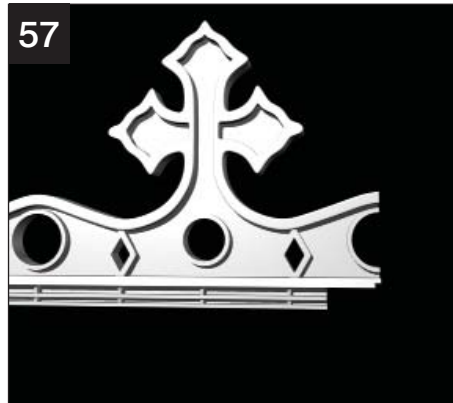

57 Cut back the underside of the last section of crestring by 40mm.

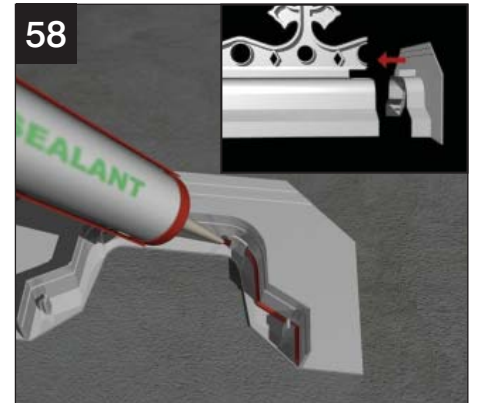

58 Apply a bead of sealant into the channel of the ridge flashing trim before fitting and then slide into position.

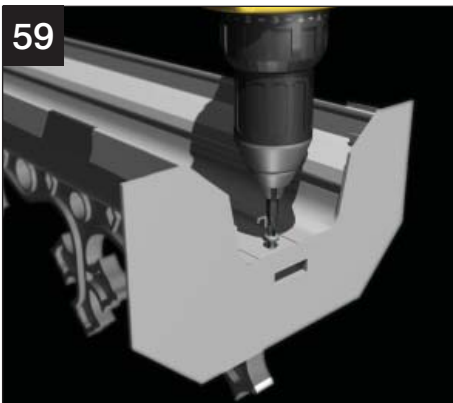

59 Screw the flashing trim to the ridge top cap through the screw port. Use a 4.2mm x 13mm self drilling screw (not supplied).

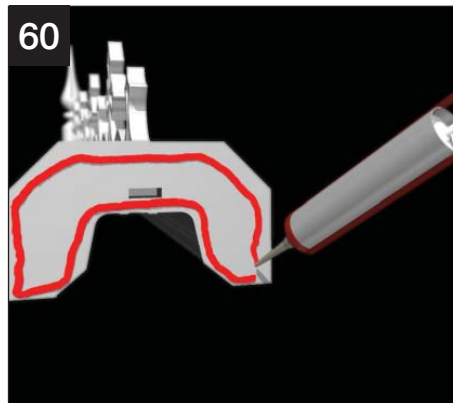

60 Apply a generous amount of sealant to the back edge of the flashing trim.

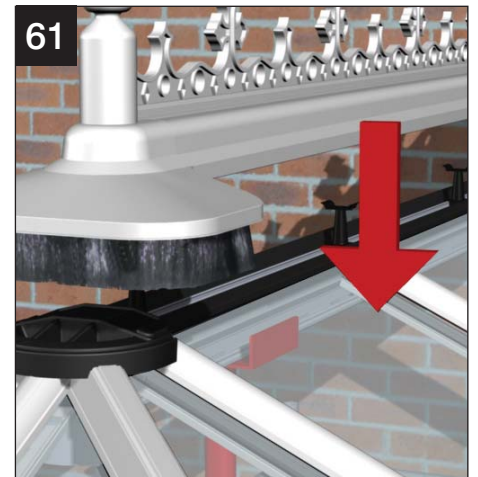

61 Offer up the complete ridge capping onto the roof.

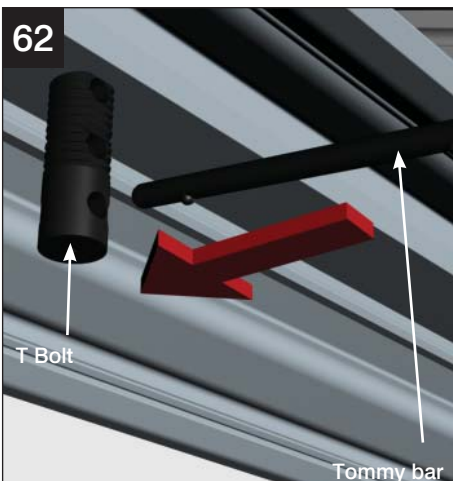

62 From the inside of the conservatory insert the snap off tommy bar into the T bolt



63 Twist through 90° to locate the T bolt into the ridge capping.

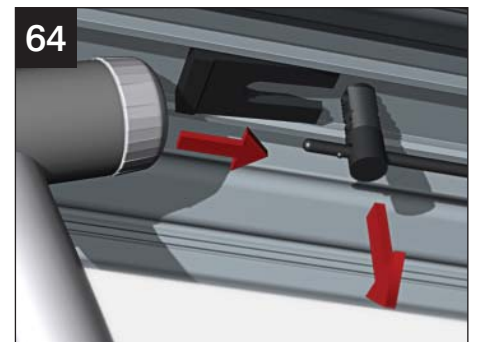

64 Pull down on the T bolt and tap the fixing wedge into place to secure the T bolt. Cut off the excess T bolt below the fixing wedge.

**CONSERVAFLASH™**  
by ultraframe

It is at this stage that remaining stepped flashings and saddle trim are fitted

SEE PAGE 54

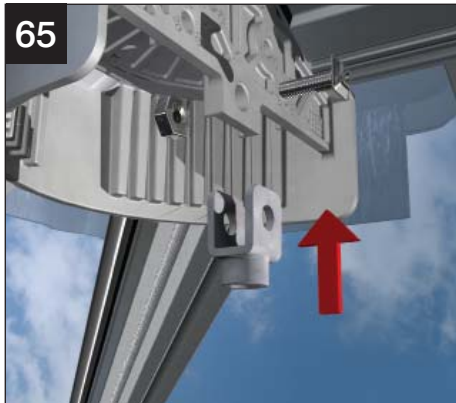

65 Attach tiebar / internal rose bracket with nut and bolt provided.



66 Using threaded rose button, attach ridge and cover end to bracket.

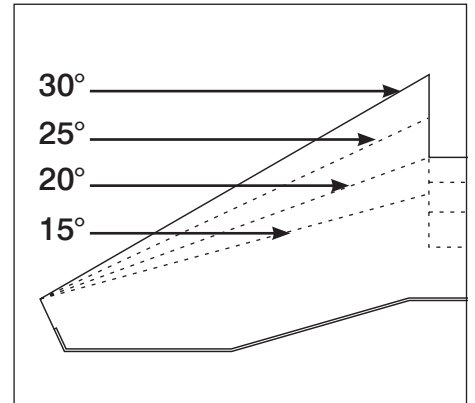

The internal radius end capping may require trimming to suit pitch (pitch lines are marked on the reverse of the internal radius end capping).

## SECONDARY OPTION

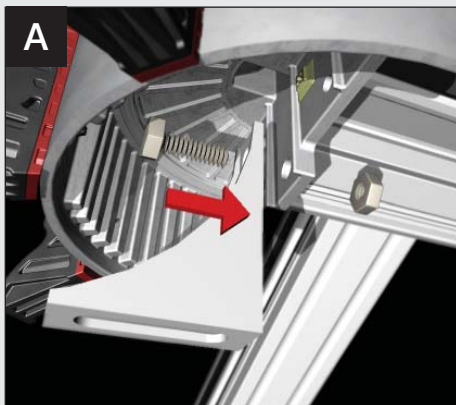

A Fit the "L" shape PVC bracket to the underside of the radius end. Offer up the internal radius end to check the position of the bracket before tightening.



B To fit the internal radius end capping insert the rose fixing button and tap the plastic rivet home to secure the button. On some occasions it may be preferable to test fit the ridge internal cladding prior to fitting the radius end capping.

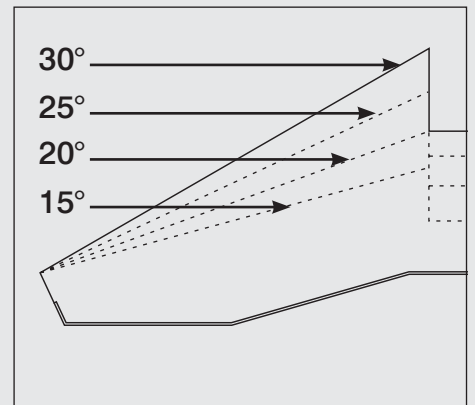

The internal radius end capping may require trimming to suit pitch (pitch lines are marked on the reverse of the internal radius end capping).

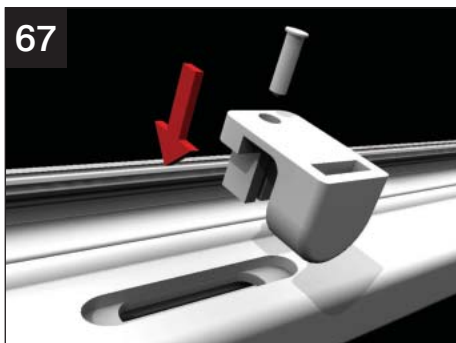

67 Ensure the ventilation button is fixed into the ridge undercladding as shown before you install the cladding.



68 Clip the internal ridge cladding onto the underside of the ridge.



69 Slot each section of internal fascia into the corner jointer and tap the fascia onto the barbs of the eaves beam. Fit Ultraselect strips into the slots in the fascia



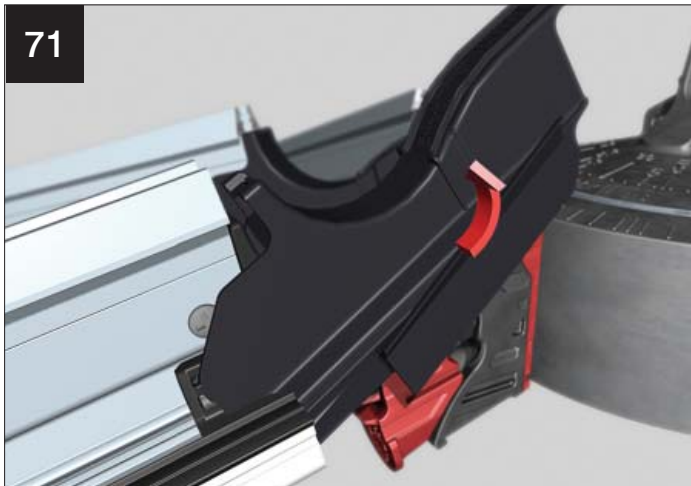

If you need to remove a glazing bar from the speedlok 2 socket assembly, remove the speedlok hood (if fitted) and release and lift the bar at the eaves end.a



Gently lever up the upper deadlock.



Insert the 5mm wide flat blade screwdriver and gently push against the upper edge of the roller cam (marked yellow).



Gently pulling the bar away will automatically release the head of the speedlok.

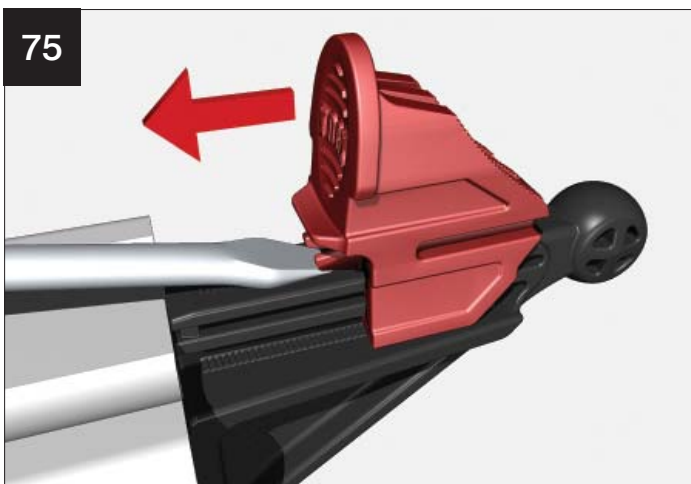

Turn the whole bar over, then insert the screwdriver blade under the lower wedge lock. Lift to allow the wedge to ride back over the serrations to its original position.

# Section 6

## TIE BAR INSTALLATION

1

When a tie bar is specified, it is a structural requirement and must be fitted.

Prior to starting installation check the ridge is level and the side frames are plumb. THIS IS CRITICAL TO THE SUCCESS OF THE OVERALL INSTALLATION.

The position of the tie bar (s) will be indicated on the location plan provided whilst the tie bar brackets are already attached to the glazing bars.

Steps 2 & 3 and 5 & 6 show installation back from finial point. To install at finial point see illustration right.

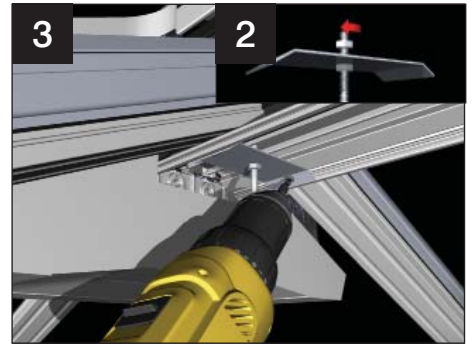
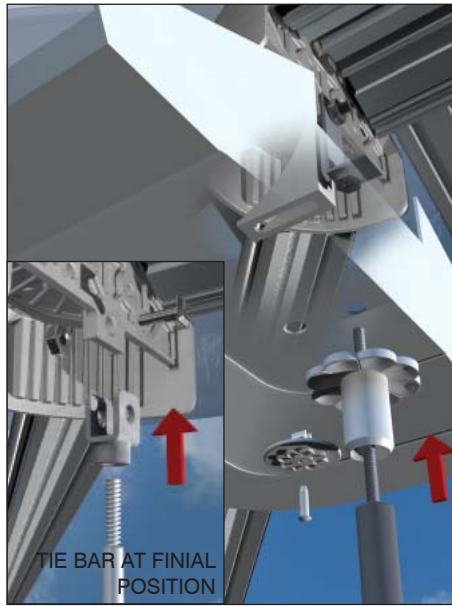

Measure the drop for the vertical threaded bar and cut to length. Attach the gusset plate to the threaded bar with the nyloc nuts provided. Ensure spanner tight. Now fit the gusset plate to the aluminium ridge body using the four screws provided. Make sure it lines up with the centre line of the pre - attached tie bar brackets. At this stage the pvc ridge undercladding needs fitting. Drill an 11mm hole in it and clip the pvc ridge undercladding into place.

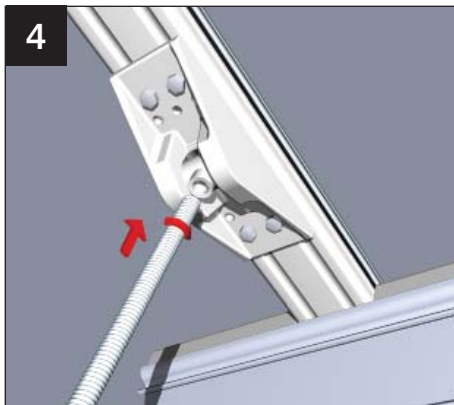

Measure, cut and attach the horizontal threaded bars (ensure sufficient engagement of the bar into the brackets) – it is essential that the tie bar boss is central. Take the boss ring, and loosely assemble the threaded bars to check they terminate inside the ring. Dis-assemble.

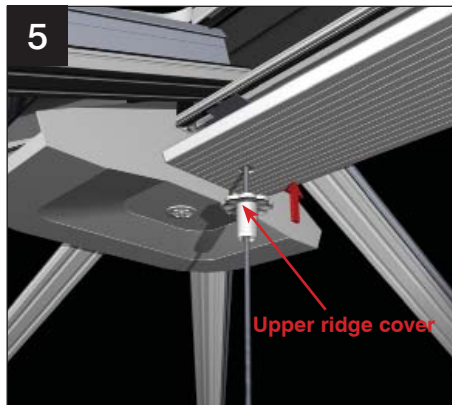

Slide the upper ridge cover over the piece of vertical threaded bar, and insert into the ridge undercladding (the hole may need 'opening' a little –ensure a snug fit).



Now cut the pvc conduit to length, taking care to make allowances for its inset into both the bracket and boss. Take the piece of vertical pvc conduit and slide over the threaded bar and push it home into the ridge cover.

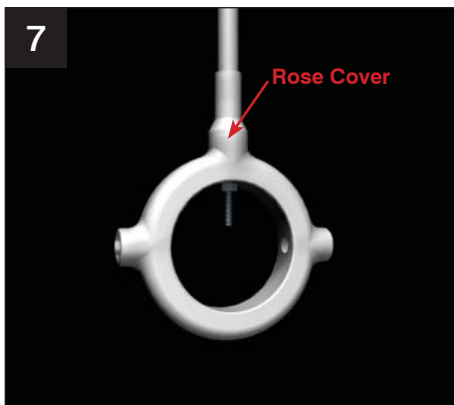

Insert the smaller diameter pieces of pvc conduit inside and then add a rose cover. Offer into the boss ring and finger tighten the nyloc nut.

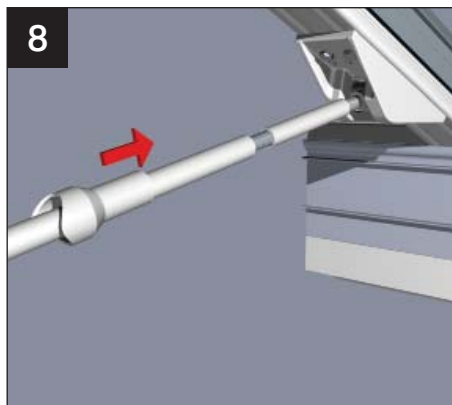

Offer up the horizontal pieces of pvc conduit (large and small diameter) and include a rose cover.

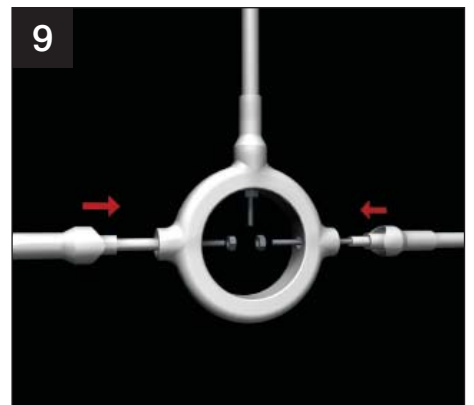

Insert threaded bar into the ring, and again finger tighten the nyloc nuts.



## TIE BAR INSTALLATION

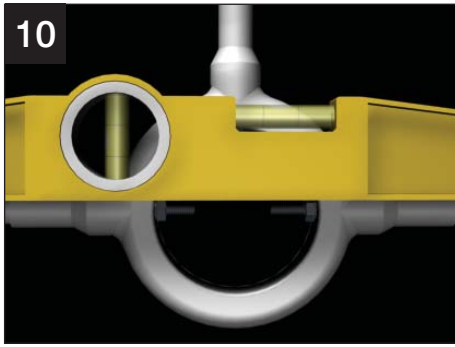

Now, finally check that the horizontal elements are level and the vertical element is plumb. CHECK THAT THE SIDE FRAMES ARE STILL PLUMB. Spanner tighten the boss nyloc nuts.

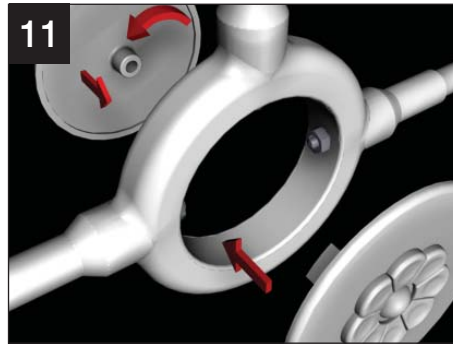

Offer up the two part rose cover, spin one half onto the threaded end of the other half.

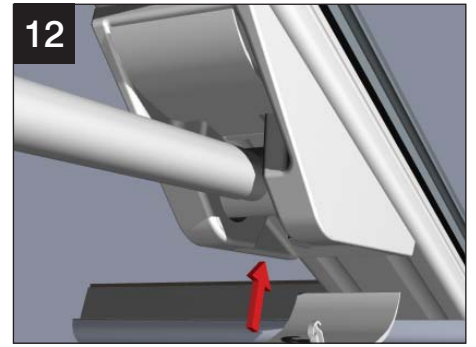

Attach the bracket cover plates that hide the bolts.

## BOX GUTTER INSTALLATION

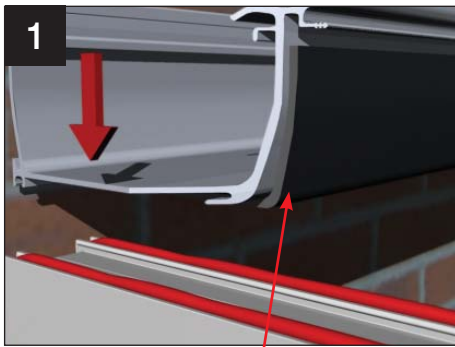

Box gutter foam to be cut back 70mm to enable the box gutter to sit flush on the frames.

Apply a continuous bead of appropriate sealant to the front and inner legs of the window frames. Lift insulated box gutter into position – ensure it has adequate support whilst fitting.



Place eaves beam section – with undergutter trim attached – onto the side frames. Seal the joint between the eaves beam and box gutter.



Whilst ensuring that its level, drill through the back edge of the aluminium at 600mm centres. Bolt to the house wall using masonry anchors that are suitable for the substrate.



Either peel back or knife off a small amount of the insulation where the cleat is to be fixed. Drill a 4.5mm pilot hole and then fix the cleats with the two M5 12mm taptite screws provided.. The protruding taptite screws will need trimming back prior to fixing the adaptor ( alternatively, when its time to insert the adaptor, undue the taptites, drill a pilot hole through the adaptor and then re-screw the taptites and fully seal).

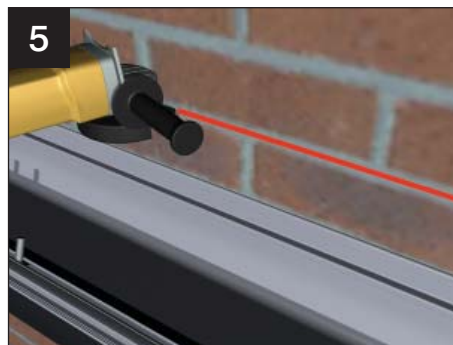

Mark out and grind a channel in the masonry for the flashing – blow out any dust in the channel.

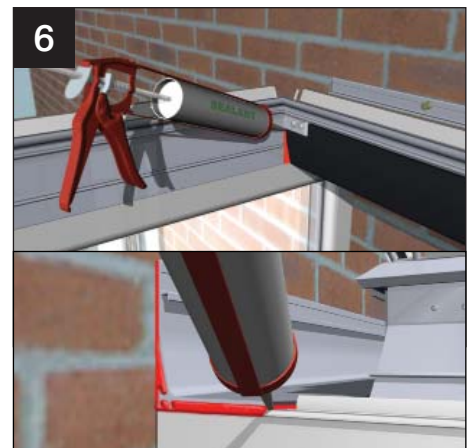

Now seal the internal joint between the eaves beam and box gutter and back point the leading edge of the box gutter where it sits on the side frames. Knife off a small section of the undergutter trim in preparation for the insertion of the adaptor.

# Section 7

# Section 7

## BOX GUTTER INSTALLATION

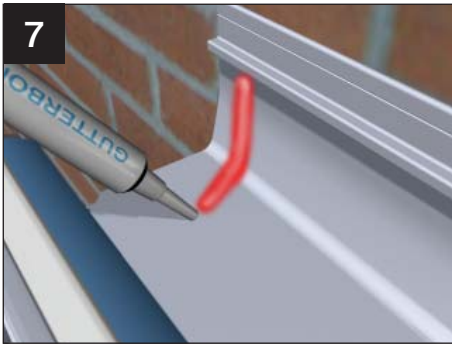

Now, from the bag in which the adaptor is supplied, take the special tube of sealant, Gutterbond. Apply a generous bead of it evenly across the mouth of the box gutter, 20mm back from the front edge.



Slide the adaptor into the aluminium box gutter, raising up its front edge to utilise the unique 'snow plough' effect. This spreads the Gutterbond evenly under the adaptor. Push the adaptor firmly up to its end stop, so that it will line through with the Classic gutter attached to the eaves beam.



With the adaptor tight to the end stop, turn the toggles upwards to firmly press the adaptor into the Gutterbond.

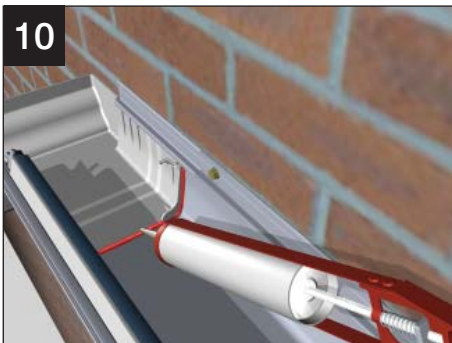

Use the balance of the Gutterbond to back point any gaps at the front edge.

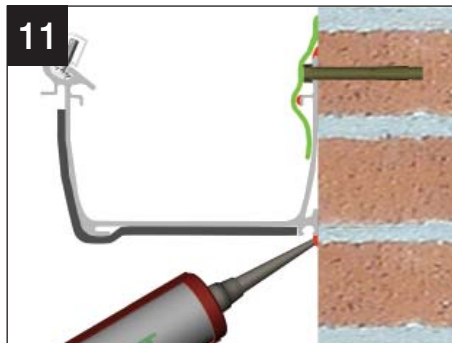

Seal the top and bottom edges of the aluminium box gutter, where it abuts the house wall.

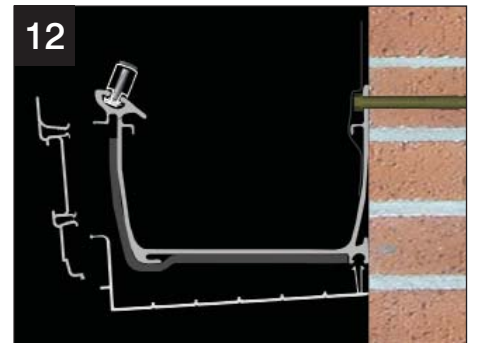

Before lifting into position, assemble the fascia board and undercladding. Offer up the undercladding rear legs, and knock up into position. Lastly locate the upper legs of the fascia board on to the box gutter. Finally seal the undercladding against the house wall.

## BOX GUTTER JOINTING

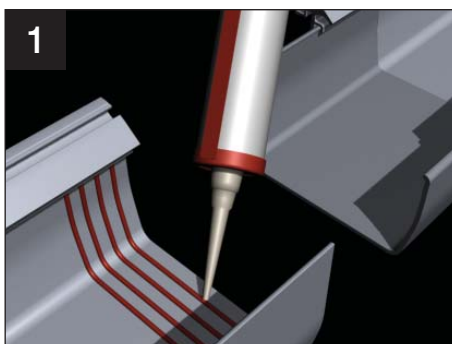

Thoroughly clean the mating parts using wire wool. Surfaces must be clean and grease free. Apply a generous bead of low modulus neutral cure to the pre-fixed internal sleeve along the entire face of the sleeve.



Drill through the top edge of the aluminium box gutter at 600mm centres. A fixing must be positioned within 50mm each side of the joint. Offer second half of the box gutter up to the internal sleeve and push firmly on. Fasten this second box gutter run to the host wall with masonry anchors suitable to the substrate. Ensure both sections are level and flush.

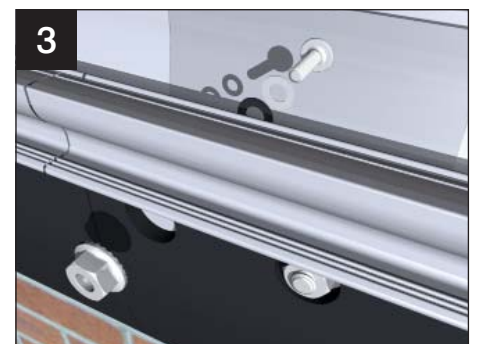

Drill 6.5mm holes through the box gutter and sleeve (at positions shown, ensuring both halves of the box gutter are flush together) and fix using the bolts, nuts and washers provided and in the order shown. Trim any excess off the bolt head before fitting the internal cladding as it may foul.



## BOX GUTTER JOINTING

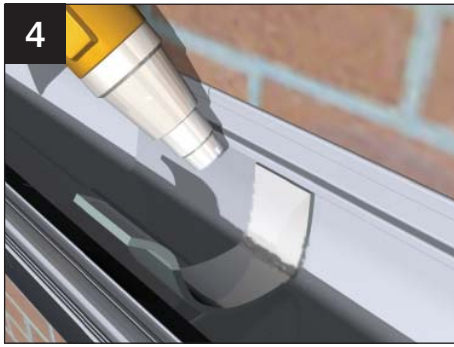

4  
Check surfaces are dry, clean and grease free. De-grease if necessary. Heat both the sealing tape and the box gutter with a heat gun and position the tape over the joint. Press the tape firmly across the joint of the sleeve and the box gutter ensuring there are no air pockets.

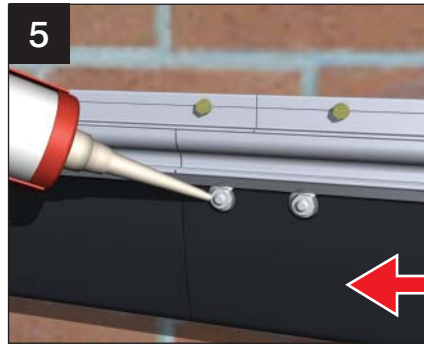

5  
Now seal over all the exposed bolt heads, on the inside and outside of the box gutter.

**ALL box gutters (especially those with tie bars or joints) MUST be supported.**

Ultraframe recommends several types of support for box gutters including brick piers. Fitting a conservatory box gutter without adequate support will lead to structural failure. Please take the correct steps BEFORE installation.

## BOX GUTTER SUPPORT

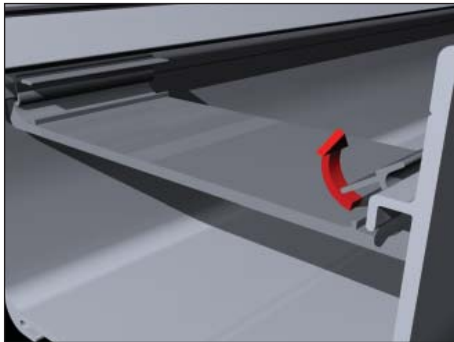

### BOX GUTTER STRAP

#### 165mm box gutters

These are supplied loose and **MUST BE FITTED** – they are a structural requirement of the roof. The straps must be installed within 75mm of glazing bar centres (when measured from centre of the strap to the centre of the bar). To install these straps, simply ‘nip up’ as shown.

#### 265mm/special box gutters

Straps are factory welded into position.



### BOX GUTTER HANGER

#### 165mm box gutters

If these have been specified by your company at the time of order they are supplied loose and must be fitted.

**The structural requirement for the hanging brackets are 2 x hanging brackets (sat side by side) at a maximum span of 2300mm unless the roof has a tie bar or joint on the boxgutter which should then be positioned in the same area.**

Drill through the head of the hanger into the centre of the masonry, avoiding the mortar joint if possible. Use a masonry anchor suitable for the substrate. Lead flashing should be dressed down over the hanger, and snipped around the sloped leg. To attach it to the box gutter, simply ‘nip up’ as shown.

#### 265mm box gutters

Hanger not available.



### GALLOWS BRACKET

These are available for 165/265 box gutters.

To install, notch out the insulation to ensure metal to metal contact between the extruded box gutter and gallows bracket. Offer up the gallows bracket and mark it ready to drill – always try to line up with the centre of a brick rather than a mortar joint. Drill the gallows bracket (the positions should be similar to the ones shown). Three masonry anchors should be used that are appropriate to the substrate.

Finally, notch out the undercladding, offer it into position and clip in.

**Maximum centres are 2300mm. If the roof has a tie bar installed or a joint within the box gutter, then a gallows gallows bracket should be installed directly underneath it.**

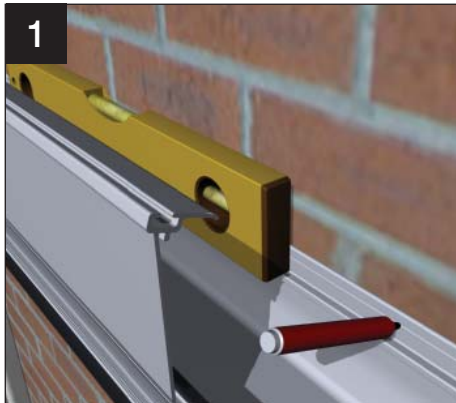

1 Offer the raised back or special box gutter into position. Carefully mark onto the aluminium leg against the host wall the position of each fixing – use 600mm maximum centres.

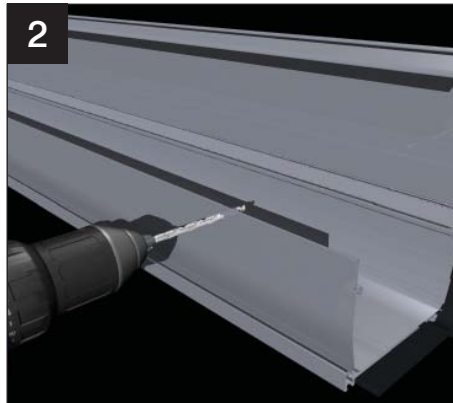

2 Lift the box gutter down to the ground and turn it around. Drill through the aluminium leg ( that abuts the host wall) at the pre-marked positions. Whilst the box gutter is on the ground, seal along the front/rear face where the deep skirt sits inside the head of the extruded box gutter.



3 Lift the box gutter back into position, check levels, and then mark the wall (through the pre-drilled holes) ready to drill the host wall and grind out for the flashing.

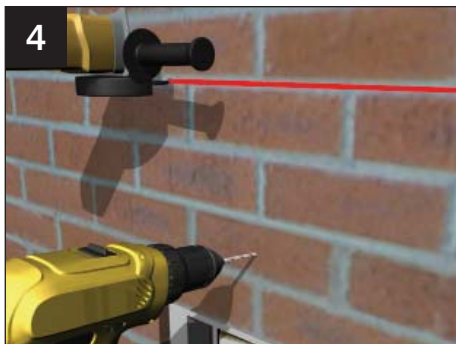

4 Remove the box gutter and drill the host wall where marked. Grind out the course which is at least one course higher than the raised back height.

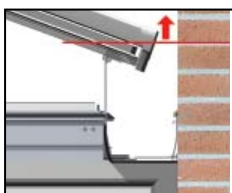

5 Offer the box gutter into position and insert the anchor fixings that are appropriate for the substrate and tighten up.

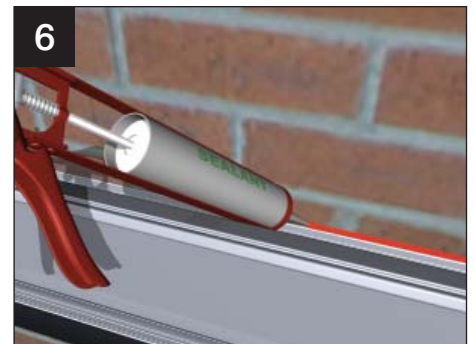

6 Seal the top and bottom edges of the box gutter and follow all other steps as per standard box gutters on page 21-22. When installing the lead flashing, ensure that the top of the flashing is higher than the point of rain water discharge from the glazing bars. Clad off the deep skirt of the raised back box gutter using multi-board (not supplied).

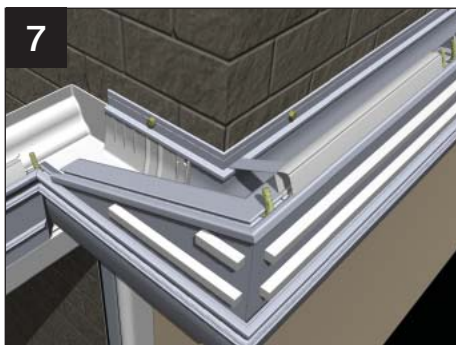

7 Following steps for the installation of box gutters on pages x-y, check that the roofing bolts are in position ( i.e top and bottom of the slope)

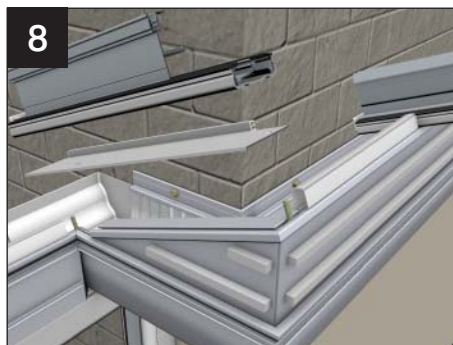

8 Place the short lengths of firing top cap and modified starter bar on to the two bolts. Please note that the bolts should be staggered, one each side of the bar.



9 Lift the `L` shaped sealed unit into position (having followed steps 33, 35 and 38 ) and carefully position. Your office may have not ordered an `L` shaped unit but may have split the unit into two, use a muntin bar to joint them (see page 34 for details of muntin bars).



## RAISED BACK BOX GUTTERS



10 Knock down the glazing bar top cap so it finishes flush with the bottom of the bar.



11 Two end caps are provided, one left hand and one right hand. Cut the end cap across its width so that it fits snugly to the face of the glass, remove it and then using the correct sealant, refit.

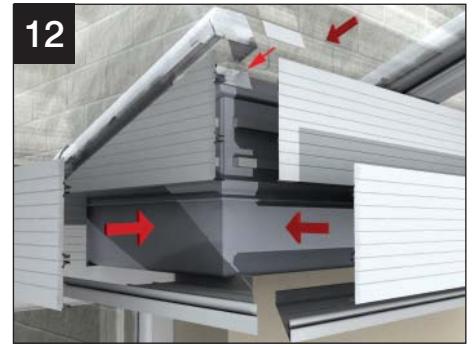

12 Internally, cloak off the open end of the glazing bar by fabricating a small end closure – seal into place. Fit the lower fascia and boxgutter claddings in the usual way. Scribe and secure the upper claddings to the factory applied horizontal sticky tape strips. (For raised back box gutters beyond 300mm in height, vertical claddings must be fabricated from your own supplied multi board).

## VALLEY INSTALLATION

# Section 8

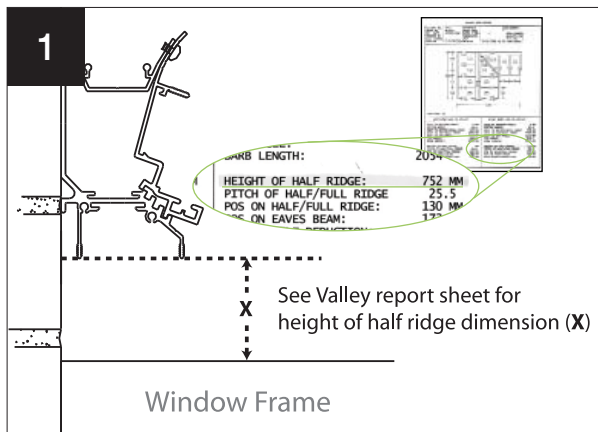

1 For exact half ridge location, please check as above.



2 Assemble as much of the main Georgian (or vic) roof side of the 'P' shape as possible. CHECK THE PITCH. Ensure the full ridge is level. Separate the two part half ridge. REMOVE THE RAIN BAFFLE UPPER LEG. Fit the back section of the half ridge in position, level across the PVC top carriages (as shown), then secure to the host wall with anchor bolts suitable for the substrate. The first anchor to be 50mm away from full ridge, the second 250mm and then at max 600mm centres.

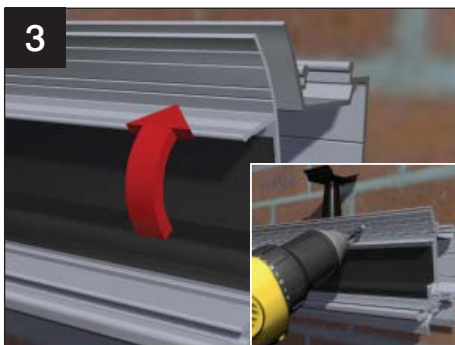

3 Re-assemble the two parts of the half ridge, ensuring that the front carriage is located in the one of six possible positions. To do this make sure that the original screw holes for the self tapping screws line up. Ensure the profile is fully engaged along its length. Use screws provided at pre-set centres to attach the two parts of the half ridge.



4 Next, pick up the aluminium valley section, ensuring the under cladding location barbs are slid into position. Then, offer the valley up to the roof and locate onto the captivated bolts in the ridge, half ridge and eaves beam. Tighten the four nuts holding the valley in place.



5 Re-fit the half ridge rain baffle. NOTE: If glazing with 24mm glass units or 25mm polycarbonate, the rain baffle upper leg needs to be set in the highest position (see step 38, p17).

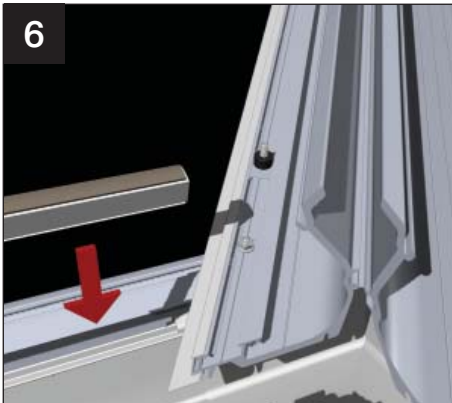

6 Re-fit the glazing support trim, where the valley meets the eaves beam.

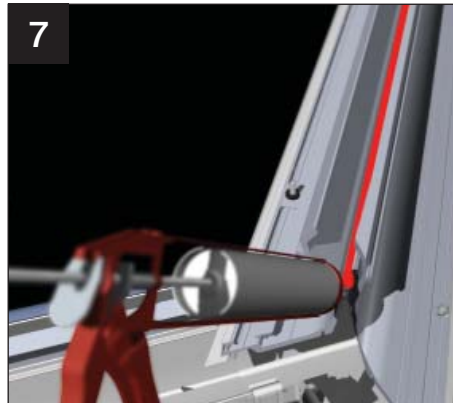

7 Now run a continuous bead of suitable silicone down the entire length of the aluminium valley profile, at the point of the hinged connector in the centre.

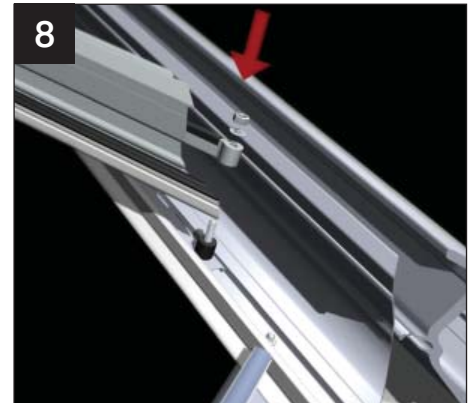

8 Using the location plan provided, assemble the various glazing bars onto the valley. Use the washers and nuts provided to ensure a robust joint is created.

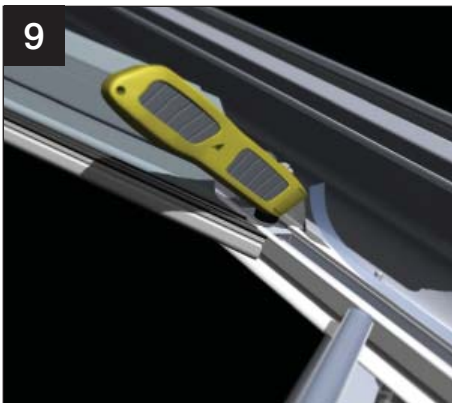

9 Fit the double sided sealing tape to each of the valley wings. Tease one end of the protective tape loose, crease it about 50mm in from the end and fold over ready to extract once the glazing panels are laid in position.

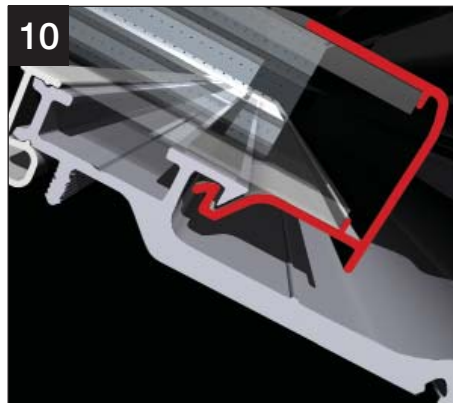

10 Place the appropriate glazing panel (refer to the location plan if in doubt) into the rain baffle of the main ridge. Then push the panel in until the glazing panel end drip locates over the barb on the valley wing.

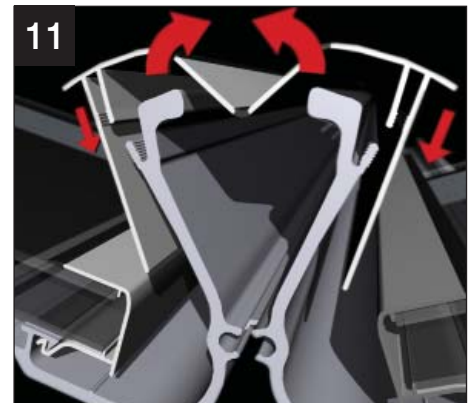

11 Fit the valley top cladding by folding to form an internal 'V' - then tap into the aluminium valley profile using a plastic hammer.

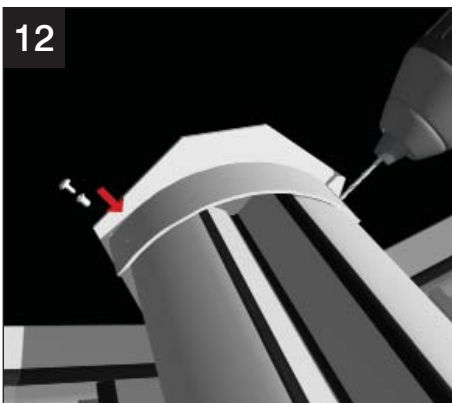

12 Fit the valley end cap using the two plastic rivets supplied.



13 The joint between the full and half ridge pvc top caps is sealed by the use of a capping connector. This needs to be trimmed to suit. Bed the capping on suitable silicone and fix using the plastic rivets provided.

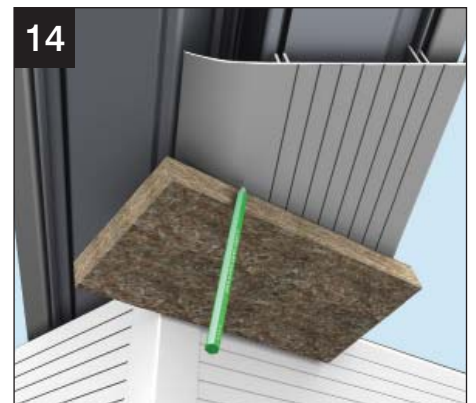

14 Cut two 200mm lengths of valley undercladding. These will act as templates for top and bottom scribes. Use a 'straight edge' placed tight to the eaves fascia board, then mark and cut.



## VALLEY INSTALLATION

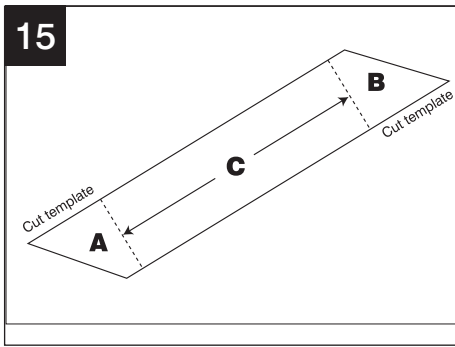

Measure dimension **C** then add **A** and **B** for overall length. Mark and cut the claddings. Repeat process for both left and right side. Push fit the claddings into position.

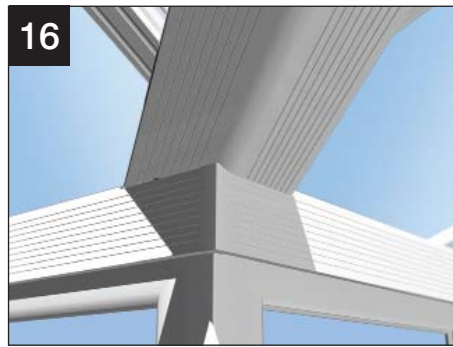

Valley claddings shown in situ at the eaves.

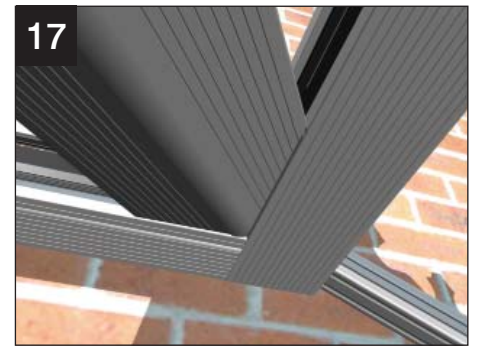

Valley claddings shown in situ at the ridge.

## HALF RIDGE INSTALLATION

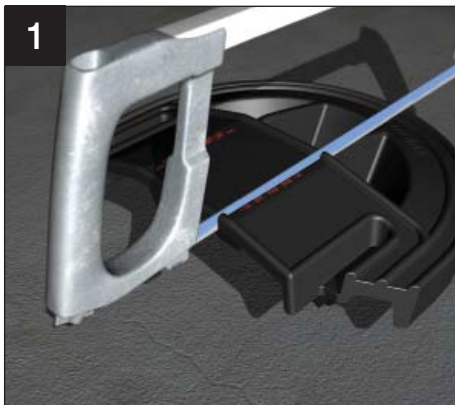

The weathering shield must be cut through the marked line. Note the illustrations shows the cut required for a left hand hipped end.



Prior to attaching the starter bar to the mounted starter bar bracket, remove the M6 tapitite screw. Locate the bar on to the bracket and on to the single bolt placed in the eaves beam, re-insert the screw.



Check the half ridge for being level and then check the starter bar pitch. Drill and fix the die cast back plate to the host wall (avoiding mortar joints) using an anchor bolt suitable for the substrate. Drill and fix the starter bars(s) (as step 31 p13).

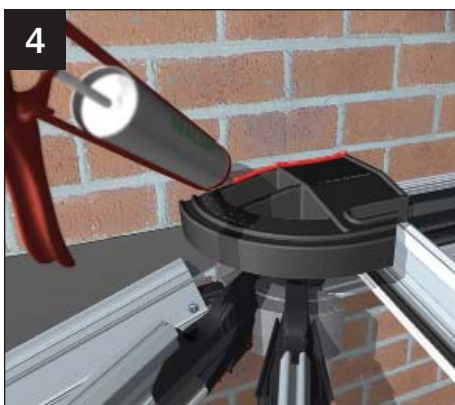

Chase out and install the lead flashing. Add the pre-cut weathering shields. Seal the weathering shield to the host wall.

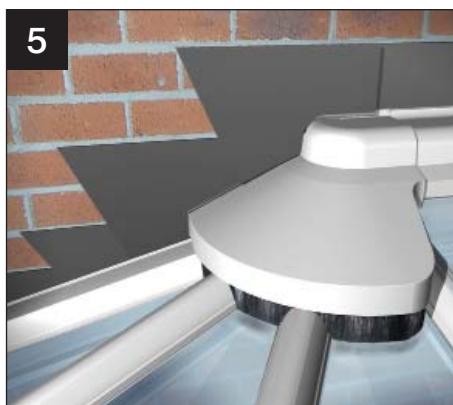

Glaze the roof. Fit and seal the top of the glazing bar top cappings. Install the ready assembled half ridge top capping and external radius end. Finally install the lead flashing to suit.



Screw threaded rose cover into the fixing 'point' mounted on the aluminium hub end.

# Section 9

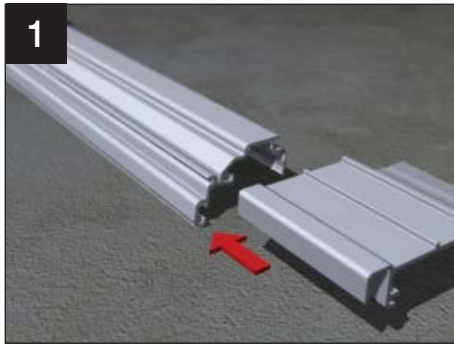

**The aluminium wallplate body has been cut to length to fit in between the side frames of the conservatory.** Slide the aluminium carriages supplied with the wallplate onto the main body and space out at approximately 500mm centres. NOTE: ROOFS WITH A PITCH OF 15° AND OVER SEE STEP 9)

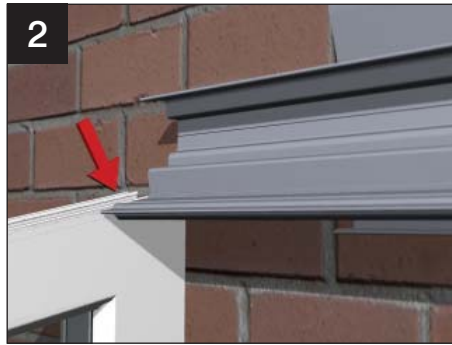

Offer the wallplate up to the wall and position it so that the top surface of the bolt slot is level with the top of the side frames.

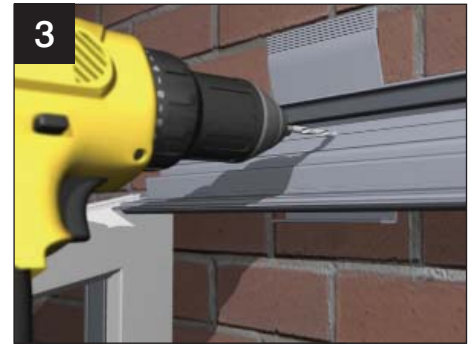

Drill through the wallplate main body and directly through each carriage to suit the masonry anchors being used (not supplied). Mark the position of each masonry anchor on the house wall and drill the house wall to suit.

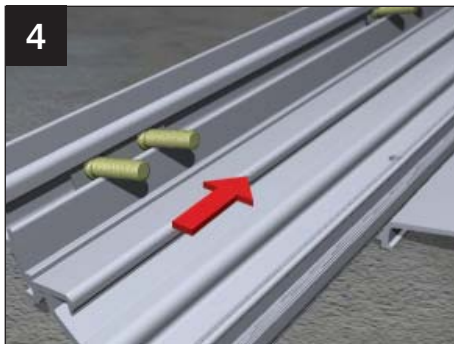

Make sure the appropriate number of roofing bolts are located in the bolt slot of the wall plate before finally fixing the wall plate to the wall.



Systematically install the masonry anchors at 500mm centres

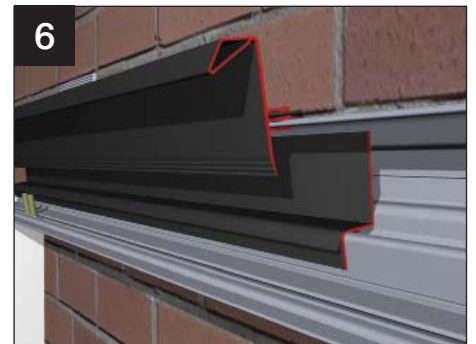

Fit the the back and main baffle. (It is pre-cut to the external frame dimension - DO NOT CUT).

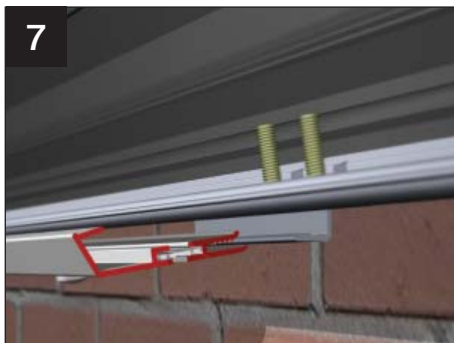

Attach undercladding, having first sub assembled the ventilation button (separate installation leaflet provided in vent button kit)

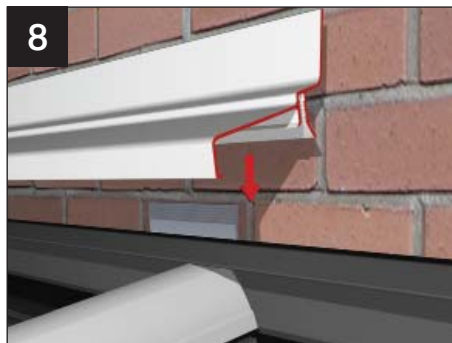

Cut the pvc wall plate top capping to the overall width of the conservatory (externally) and notch over the top of the lean-to cloaking trim at each end. Push fit the wall plate top capping. Fit the wall plate end caps using sealant appropriate to the glazing. Fit the lead flashing.

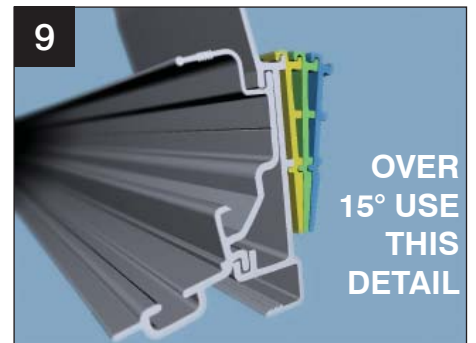

If the pitch of the roof is greater than 15° then the wall plate is supplied with a number of aluminium packers. These packers hook onto the back of each carriage and act as a wedge between the carriage and the house wall. These should be fitted when drilling and fixing the wall plate. The packers may be used in multiples and each packer will tilt the wall plate by 5°. When packers are used it will be necessary to ease the wall plate top capping back to the wall and secure with plugs and screws before dressing the lead flashing over the top capping.



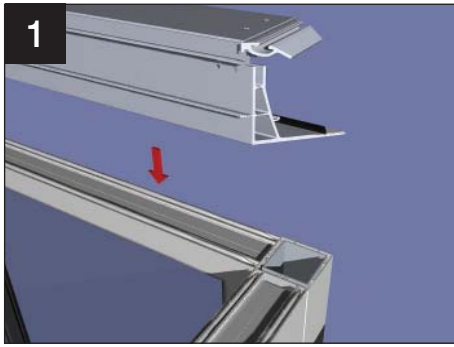

1 Trial fit the gable beam and the eaves beam ensuring the inside face is flush with the inside face of the window/door frames. Remove, then apply a continuous bead of silicone to both the front and rear edges of the window/door frames.

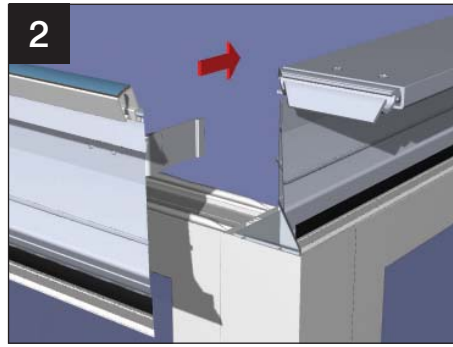

2 Fit the under gutter trim to each section of eaves beam and gable beam, position the beams and slide the corner cleats (already attached to the eaves beam) into the gable beam. Drill through the holes already in the gable beam into the gable beam. Drill through the holes already in the gable beam into the cleats and secure with the screws supplied.

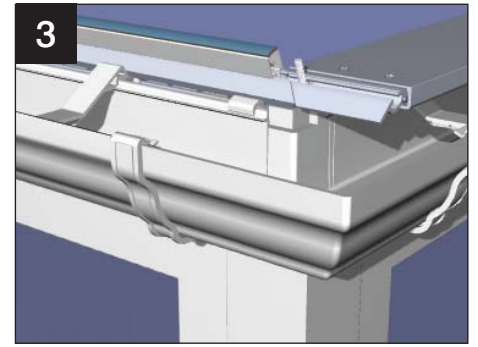

3 To secure the gable beam (see Vic Fixing Kit page 10), then at this stage the guttering is installed. First attach the gutter brackets to the gable/eaves beam. Fit the 90 degree external gutter corners to the gable beam length of gutter. The brackets are at maximum 750mm centres and 200mm from each corner.

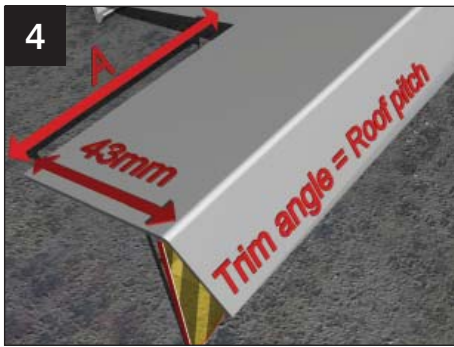

4 With the guttering in place, trim the gable beam top cladding. The cladding is supplied over length and cut to suit the roof pitch (see table).

Roof Pitch (°)	Dim A (mm)
10	83
15	85
20	87
25	89
30	93
35	98
40	104

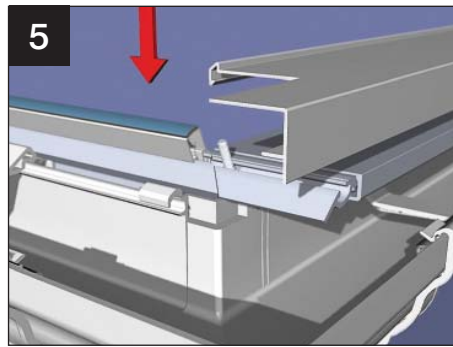

5 Next attach the notched gable beam top cladding on to the head of the gable beam.

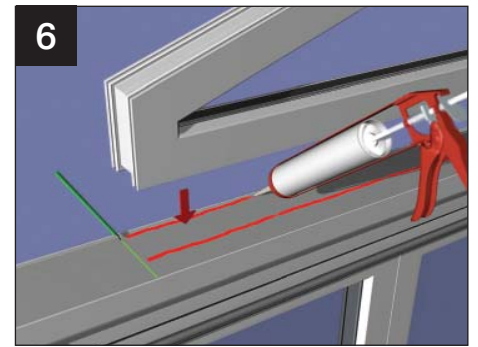

6 Position the gable window frame central to the gable beam, and mark the position. Remove the frame and again run two beads of silicone along the head of the gable beam top cladding (the width of the window frame only). Replace the frame centrally and back against the upstand of the gable beam top cladding. Fix securely through the frame into the head of the gable beam with self tapping screws (not supplied).

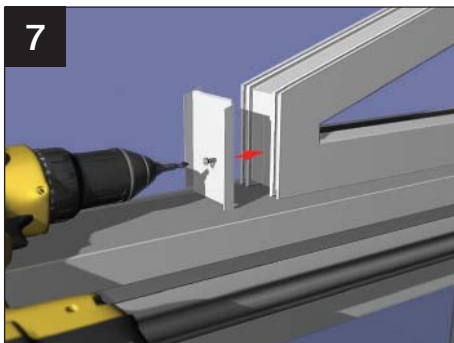

7 Mark and cut the gable infill end cap. Notch inner bottom edge to allow the end cap to sit flush and tight to the gable window frame. Trim top edge to suit pitch of roof and gable frame firing top cap which should be placed into position for marketing purposes. First silicone and then screw the end cap to the gable frame.

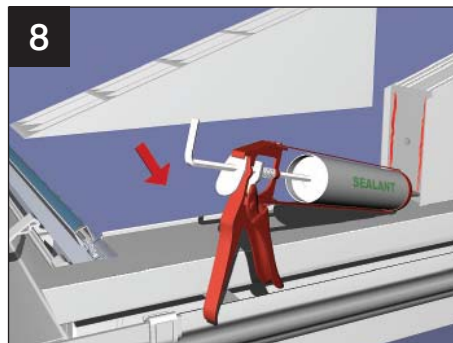
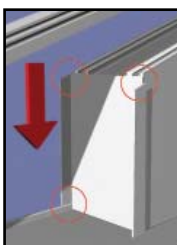

8 Trial fit the gable infill wedge. Remove, run two beads of silicone and place back in position, tight up against the infill wedge end cap. **NOTE: it will be necessary for non standard pitches to trim the infill wedge to suit the pitch, maintaining the 135mm height dimensions.**

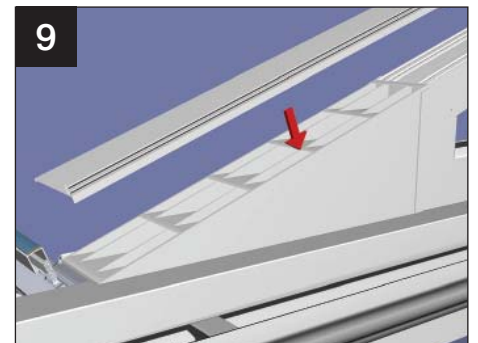

9 Position the gable frame firing top cap along the gable frame and over the infill wedge. The bottom edge of the gable frame firing top cap is cut to finish flush with the lower edge of the infill wedge and the end of the gable beam. The top edge is cut vertically to suit the roof pitch. Silicone in position.



Place and support the ridge ensuring the ridge is central to the gable frame. Place the starter bar onto the furring top cap and secure to the ridge and eaves beam. Securely fix the starter bars to the gable window frame. Fit and glaze the roof in the normal manner.

**NOTE: Ensure the gable frame is vertically plumb.**

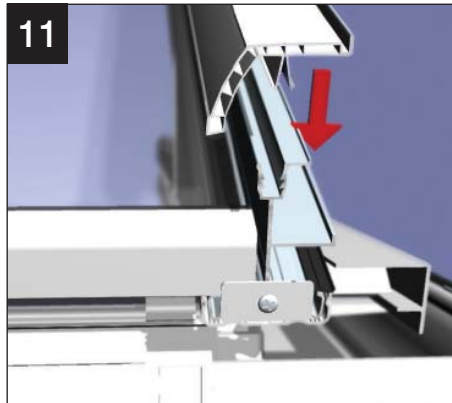

Fit the starter bar top capping in position.

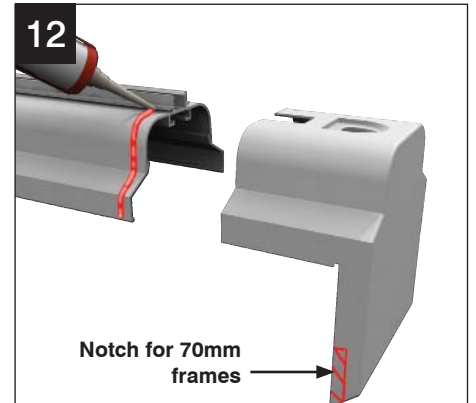

Take the gable end cap - notch if required for 70mm frames. Seal the ridge body as shown.

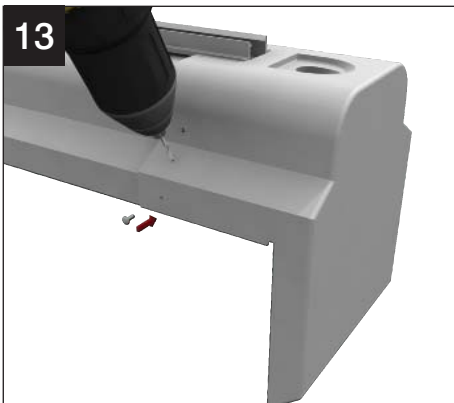

Using plastic pop rivets supplied, drill as shown and install rivets - avoid 'flat top' of profile



Follow same procedure on half ridge gable ends.

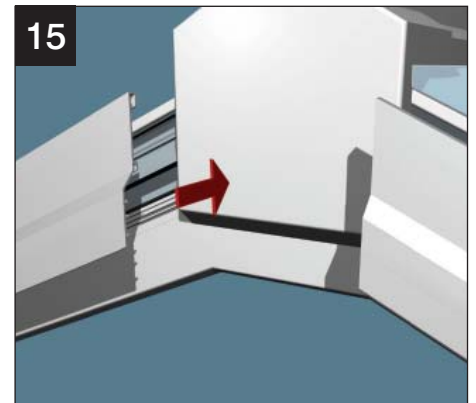

Offer the lean to cloaking trim up to the side of the gable ridge end cap and scribe to suit the roof pitch - push into place against the end cap.

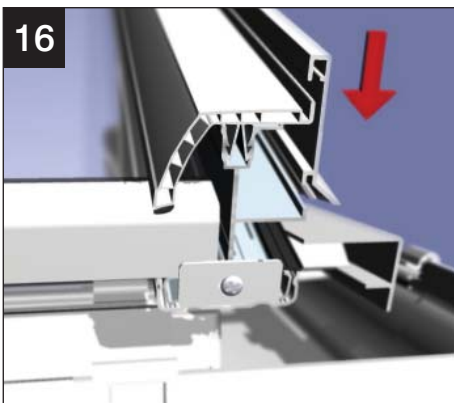

The overall length of the lean to cloaking trim is to the end of the starter bar. Cut in-line with the end of the starter bar. The tapered cut along the lower edge runs parallel with and along the gable beam top cladding.



Finally fit the starter bar end cap.



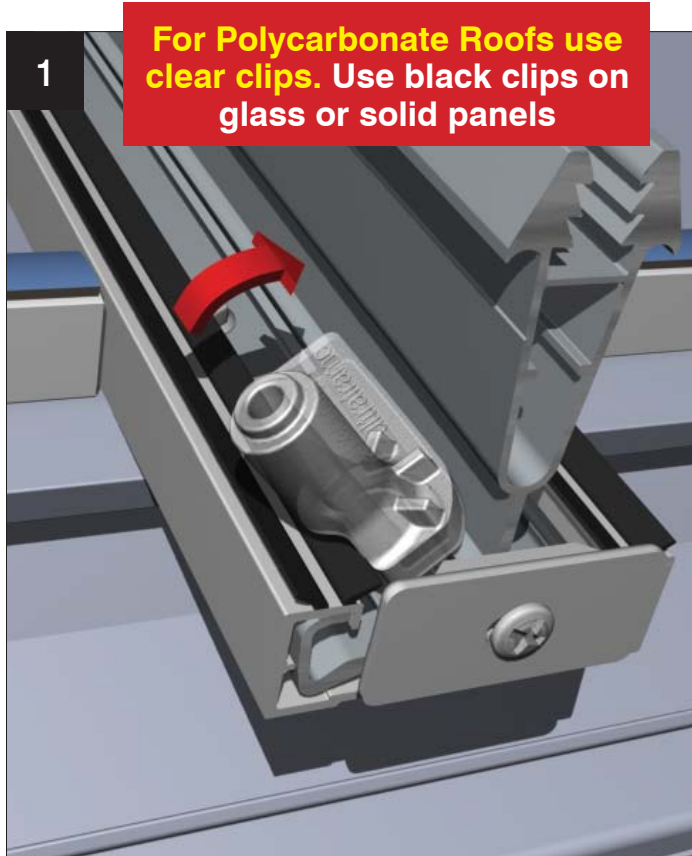

Snap off appropriate handed clip (left hand illustrated). Handing marked on base of clip. Line up the rounded edge on base plate next to central web of glazing bar then tuck neatly under gasket side of bar. Rotate clip into position.

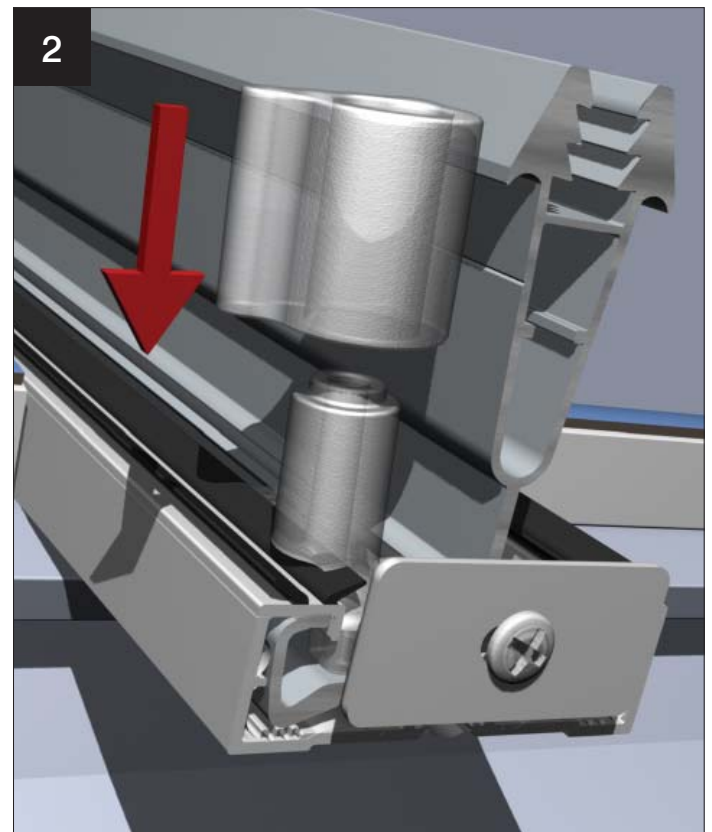

Push the grommet over the post as shown.

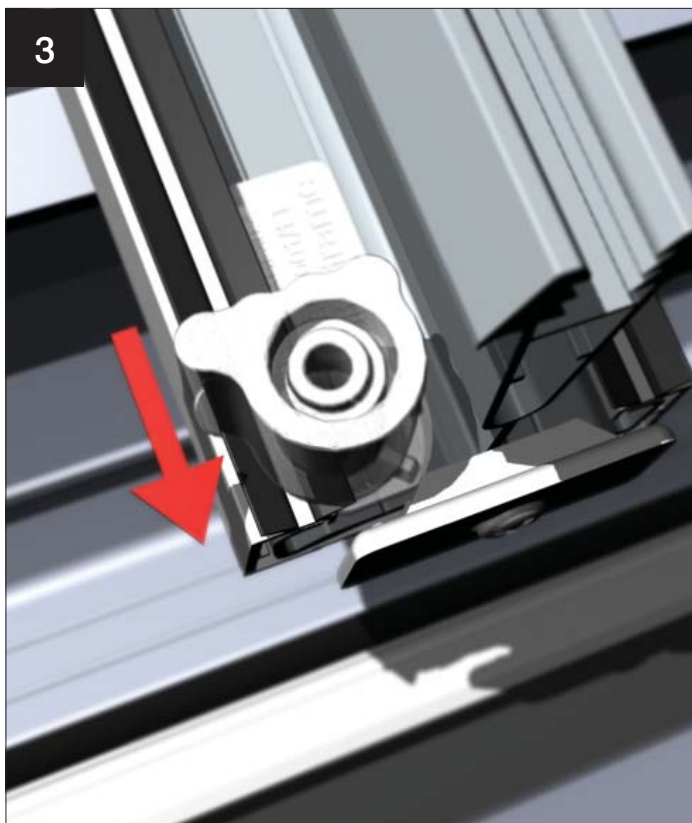

Slide the complete assembly down the glazing bar, using the fixing block as the 'stop'. Next, lift the polycarbonate panel into position and centralise it. If necessary pack it out on each side.

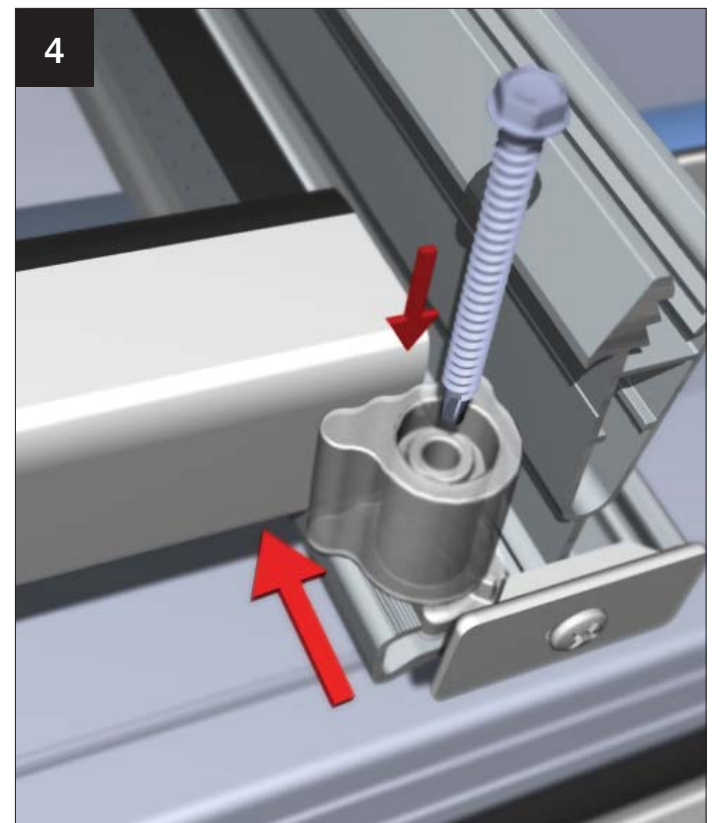

Ensure the glazing end profile sits snugly behind the grommet (if necessary slide the complete assembly up the bar to ensure contact. In exceptional circumstances the grommet may need trimming). Now, using the fixing provided screw down into the bar as shown.

**Ensure clip offers maximum support to glazing at all times.**

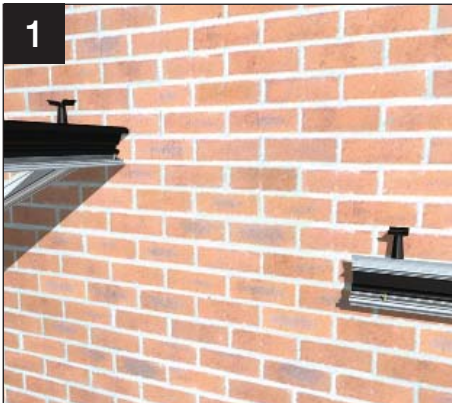

As with a standard 'P' shape, assemble as much of the main Georgian (Or Victorian) roof side as possible. Check the pitch. Ensure the full ridge is level. Offer the assembled half ridge to the host wall. Attach at least two bars from half ridge to eaves and then tighten down the nuts. Check the pitch. When pitch is correct, mark the host wall along the top edge of the half ridge.



To ensure the half is in the correct side-to-side position, either attach the hipped end starter bar and check pitch or ensure lean-to transom bars (already attached) are at 90 degrees to the eaves and half ridge. Again, mark the host wall when half ridge is set. Remove bars, separate the two part half ridge and secure the back section to the host wall (as step 2, page 28) and then re-fit the front carriage as step 3, page 28.



With the valley lowered into position (see step 4, page 24) locate the short starter bar from ridge to valley. Tighten nuts and check the pitch of the short starter bar (this should match the pitch of the other side of the main roof). Ensure ridges are level. Re-fit the half ridge rain baffle (see step 5, page 34).

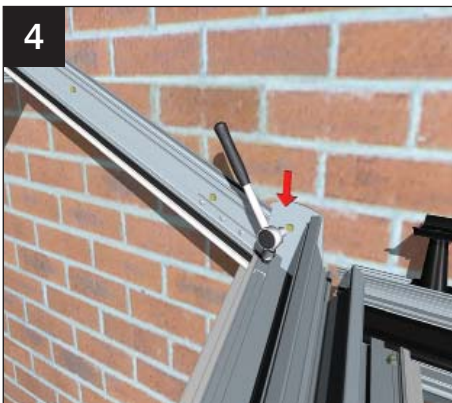

Drill and fix the valley back-plate to the host wall (avoiding a mortar joint) using an anchor bolt suitable for the substrate. Drill and fix the starter bars (as step 31, p13).



With the pre-formed soaker clipped into the starter bar, installed. The first stepped lead flashing will need to overlap onto the welded valley back plate (you may need to snip and shape around the fixing). Then continue up the slope.



With the roof now fully glazed position the half ridge top capping to suit. The 'nose' will require notching to suit the valley top capping.



Again, position and notch the half ridge end cap to suit. Attach with suitable sealant.



Fit the horizontal lengths of lead flashing along the appropriate course above the upstand of the half ridge top capping.

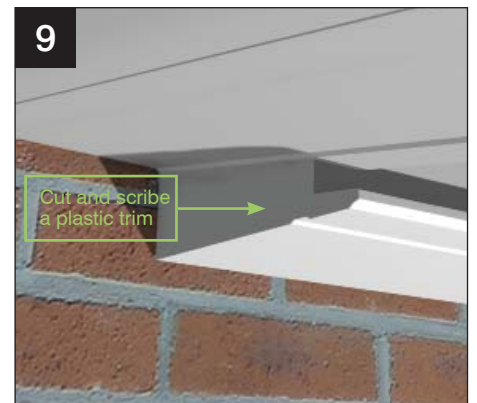

Scribe a plastic trim to close the gap between the half ridge and valley undercladdings.





The aluminium bolster is already attached to the glazing bar, and is a little shorter than its host.

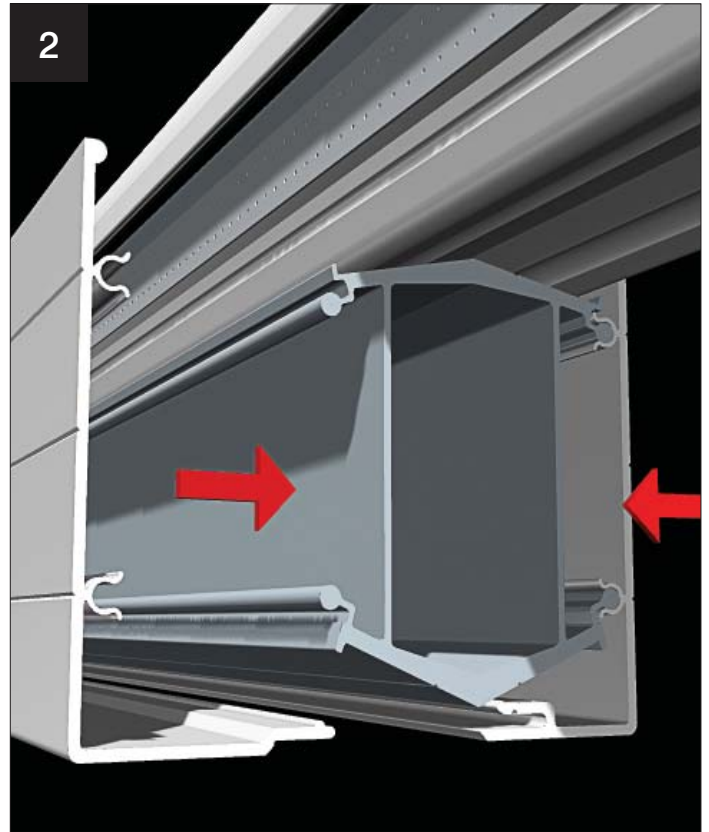

Take the two part cladding, attach each piece carefully to the aluminium bolster profile and 'zip' together.

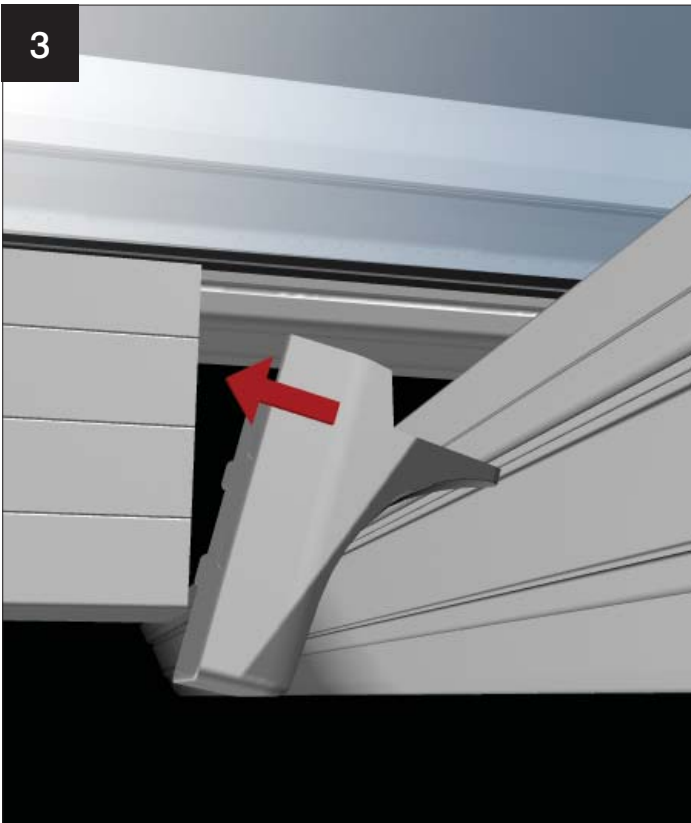

Next take each bolster end cap, simply plug into the pvc bolster cladding – one at the ridge one at the eaves.



This is how the finished arrangement should look.



IF YOUR SEALED UNITS HAVE BEEN SUPPLIED WITH TAPED EDGES, ALWAYS REMOVE THE TAPE PRIOR TO INSTALLATION. Take the muntin bar profile (top and bottom section) that matches its corresponding sealed unit. Take the lower section and allow it to span between the two adjacent glazing bars. Lower into position the up slope sealed unit. NOTE: MUNTIN SHOULD BE SAME WIDTH AS UNIT.

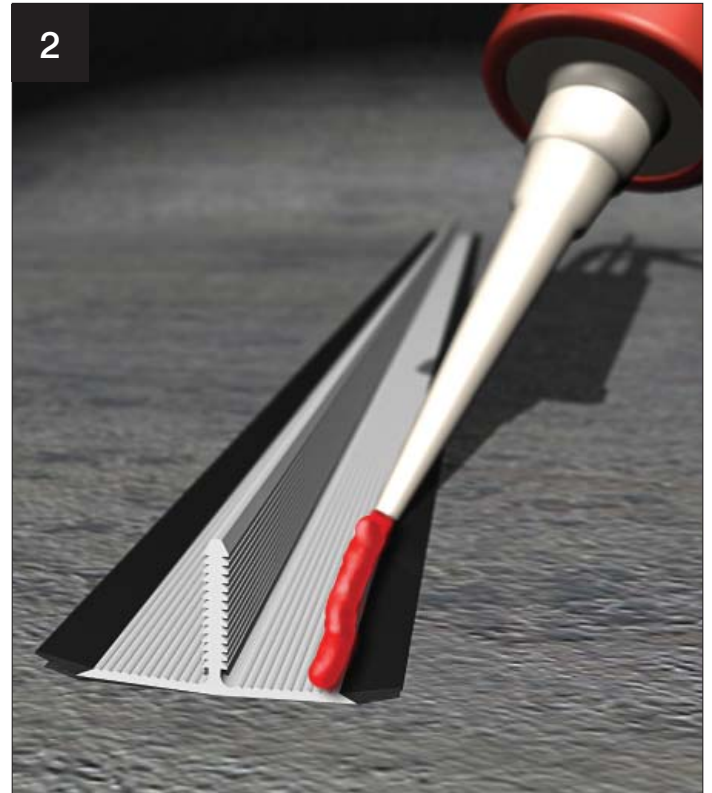

Now take the upper section and lay it face down onto a smooth clean surface. Using the relevant sealant (MS Polymer sealant such as Rotabond 2000 must be used on self cleaning glass), apply a generous bead to each side, immediately behind the gasket.

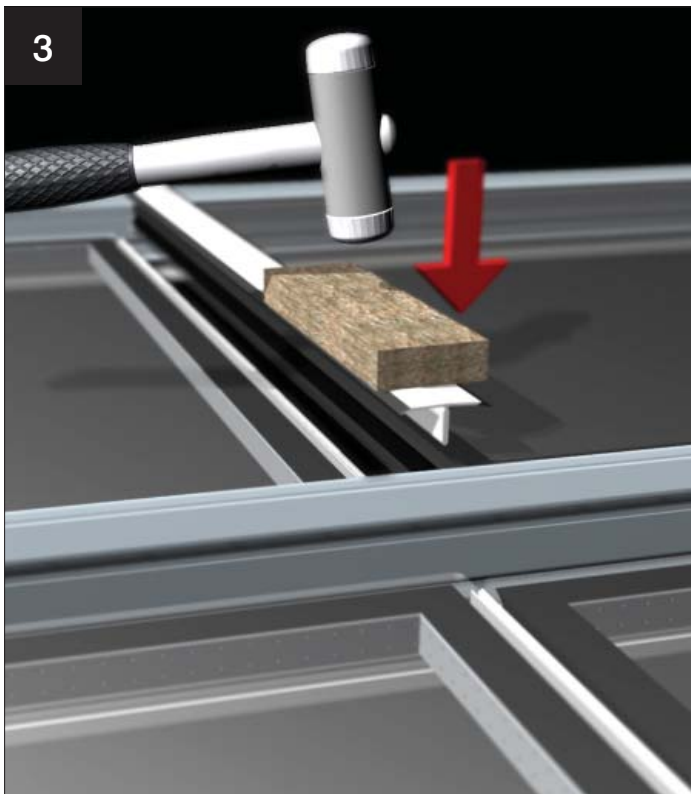

Now lift the sealed unit that goes on the lower slope into position, turn the upper profile over, place it into position and tap down the profile using a non marking plastic mallet. Wipe clean any sealant from the unit face. NOTE: WE RECOMMEND A SECOND PERSON TO SUPPORT THE MUNTIN FROM THE UNDERSIDE WHEN TAPPING DOWN.

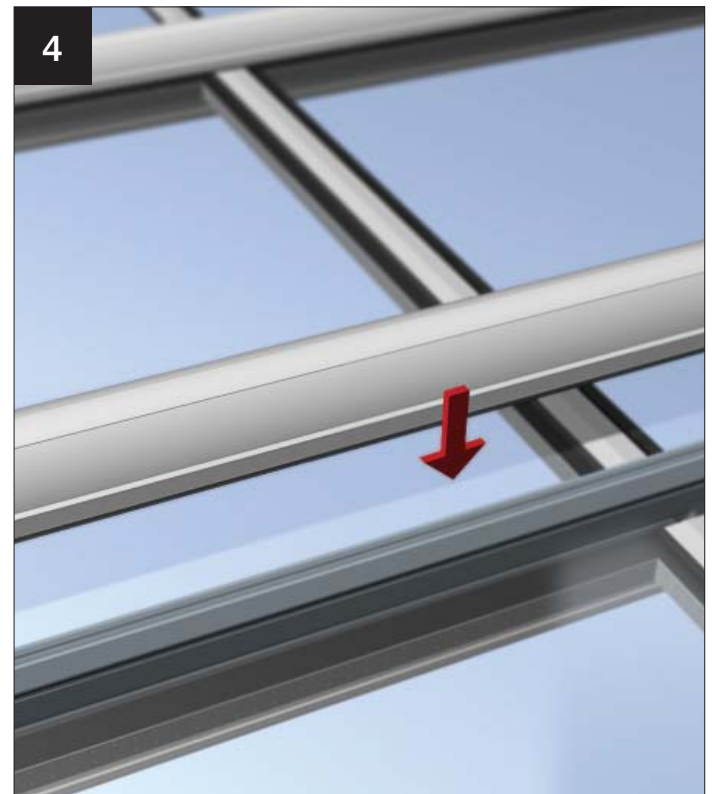

Now, tap the pvc top cap into position, which will 'trap' the muntin profiles.



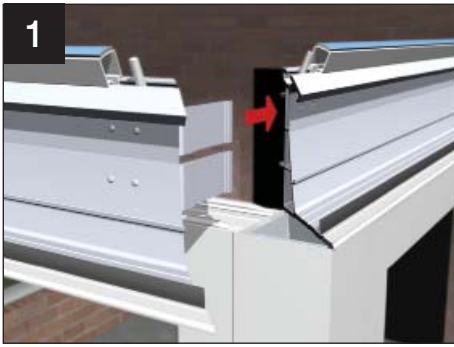

Each eaves corner (90°, 135° and 150°) is supplied pre-fitted with two standard cleats (Georgian 90° illustrated).



Two pilot holes already exist in the next piece of eaves beam – drill two more at 4.5mm diameter through the eaves beam and the cleat and then securely fit the four M5 x 12mm taptite screws.



Where the eaves beam sits against the host masonry wall, it has a structural moulding attached to the eaves beam. This has three fixing positions cast into it to allow attachment into masonry – choose the hole that directly lines up with solid masonry and drill a 10mm hole into the host wall. Attach the structural moulding using the M8x80mm anchor supplied. Silicone seal the gap where the moulding attaches to the eaves beam.



On the ground, away from the conservatory, offer up the first starter bar. Fasten using the set screws provided - do not over tighten.



Take the second starter bar and similarly offer this onto the ridge hanger/compression plate assembly. Lift the whole "A" frame assembly and get ready to install it in its final position.

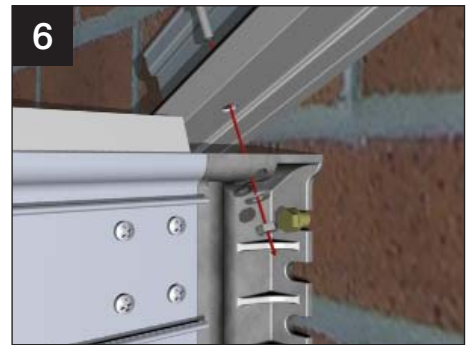

Attach the starter bar using the nut, bolt and spring washer (included in the kit) to the eaves structural moulding. Finger tighten the nut to temporarily allow the assembly to hang.



To set the height of the ridge, refer to the component location plan which states the height from the top of the frames to the underside of the ridge hanger. For added peace of mind use an "angle fix" check the starter bars are at the correct pitch. Chalk/pencil a line on to the wall to mark the pitch line.

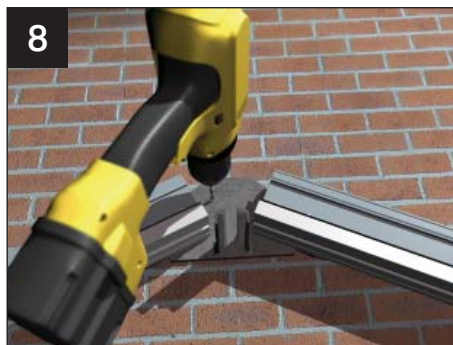

Attach the ridge hanger/compression plate to the host wall. Drill the plate with 2 x 9mm holes, then the wall with an 8mm masonry bit and fasten into the masonry using the two M6 x 65mm sleeve anchors (or resin anchors) provided. If necessary, use aluminium shims to pack out behind the plate. Check the plate is vertical and securely fastened. AT THIS STAGE IT IS ADVISABLE TO CHASE OUT FOR CONSERVAFLASH /LEAD FLASHING.



Loosen the "crocodile jaw" bolts on the underside of the main ridge body – ensure it is supported at the front whilst it is gently guided onto the top half of the 'crocodile jaw'.

Note: The starter bar is NOT attached (bolted) to the ridge body.

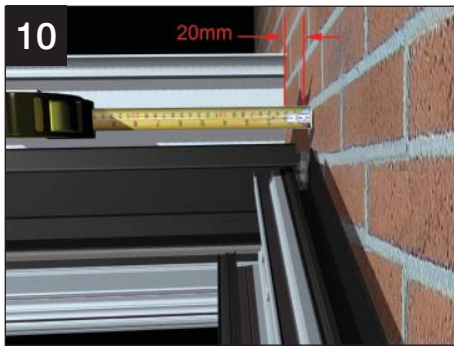

The ridge body should ideally sit 20mm back from the house wall (or 12mm from the front plate), this allows the compression plate to evenly distribute ridge loads into the host wall (max tolerance 50mm). If the host wall is out of plumb, pack out behind the starter bars and use the longer bolts provided. This ensures the starter bars are at 90° to ridge body (and not tapering).

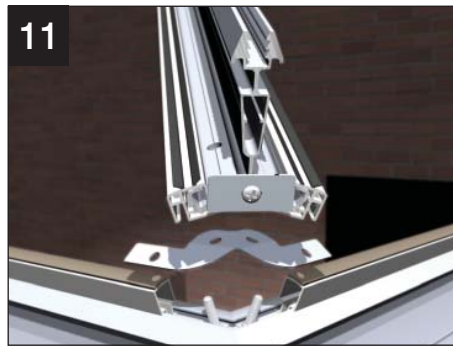

Lay the butterfly cleat over the two captivated roofing bolts at the eaves and lay it onto the slotted ridge end. Note: A butterfly cleat is not required on 3 or 5 facet fronts unless the eaves beam joins a box gutter at the facet joint.

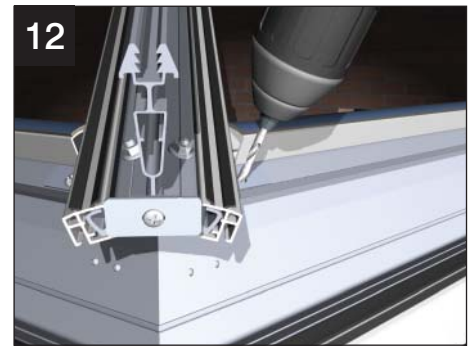

Drill a 5.5mm hole and then fix the 'butterfly' cleat into the head of the eaves beam at the 90 degree corners using the fixing provided.



Ensure that the fixing on the eaves moulding and the nuts on the 'crocodile hanger' are tightened up. Also ensure the bolts at the top of the starter bar, are tightened up.



Drill an 11mm hole through the aluminium starter and its factory inserted reinforcement. Then use a 10mm masonry drill bit for the host masonry.



IT IS IMPORTANT THAT AN ANCHOR BOLT GOES INBOARD AND OUTBOARD OF THE EAVES BEAM.

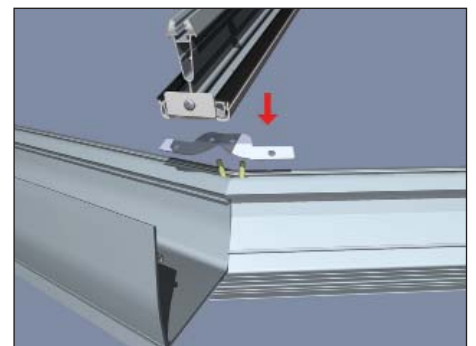

### 135° EAVES AND BOX GUTTER ASSEMBLY

Place the 135° butterfly strap (SES004) over the roofing bolts. Offer the glazing bar on to the bolts, align and secure. Once in position fix the strap down with the two fixings supplied (UZBGF001-D).

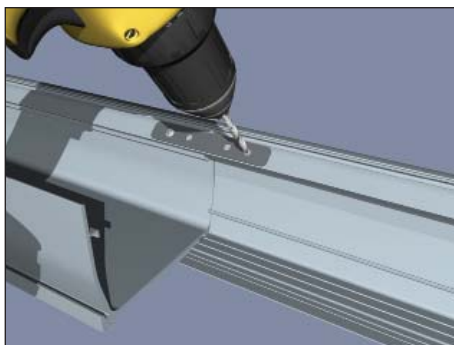

### 180° INLINE EAVES AND BOX GUTTER ASSEMBLY

Place the inline cleat (SES002) over the butt joint. Fix down either side of the joint with the two fixings supplied (UZBGF001-D).

Note: Only two of the four holes need to be used.

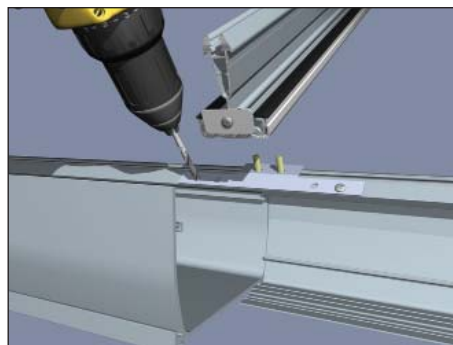

### 90° EAVES AND RAISED BACK BOX GUTTER ASSEMBLY

Place the inline cleat (SES003) over the butt joint. Offer the glazing bar on to the bolts, align and secure. Once in position fix the cleat down with the two fixings supplied (UZBGF001-D).

Note: Only two of the four holes are used.

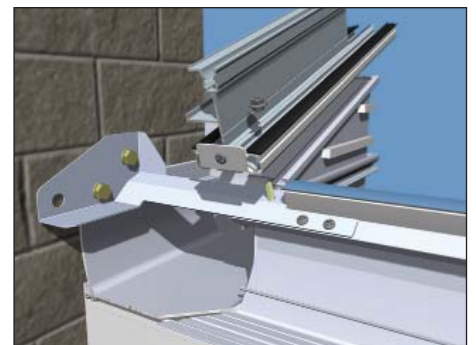

### 180° INLINE EAVES TO BOX GUTTER JOINT

Place the inline strap (SES005, 165mm / SES006, 265mm) over the single roofing bolt on the sloped gutter. Temporarily fix the bracket to the host wall using three M8 sleeve anchor bolts (SAB001) supplied. Fit the starter bar. Secure the strap to the eaves with the two fixings supplied (UZBGF001-D). Finally, fix anchor bolts.



**Note to Fitters – carefully follow these notes but follow section 4 simultaneously to get a perfect ‘right first time’ installation.**

1. Support the die cast aluminium hub.
2. Offer up the glazing bars, starting in the four opposing corners to ensure the hub is supported.
3. Follow steps 13-16 on page 12, attaching all the glazing bars.
4. Check the hub ‘wok’ is level and plumb – now use your thumb to push up all the lower wedge locks. The roof is now set.
5. Once the roof is glazed and the pvc top caps are knocked on, now is the time to fit the ‘soft touch’ hub weathering shield. It may be necessary to ‘snip’ small cuts in the shield to facilitate top caps seating correctly.
6. Seal around each glazing bar top cap where it meets the inner wall of the shield. Apply a bead of sealant to the top edge of the shield so that the ‘wok’ cap is sealed correctly.
7. Drop the pvc ‘wok’ top cap into position, apply a bead of sealant to underside of finial and screw the finial into position through the top cap.
8. Internally, offer up the pvc ‘wok’ cover over the threaded bar and screw the rose cover onto it.

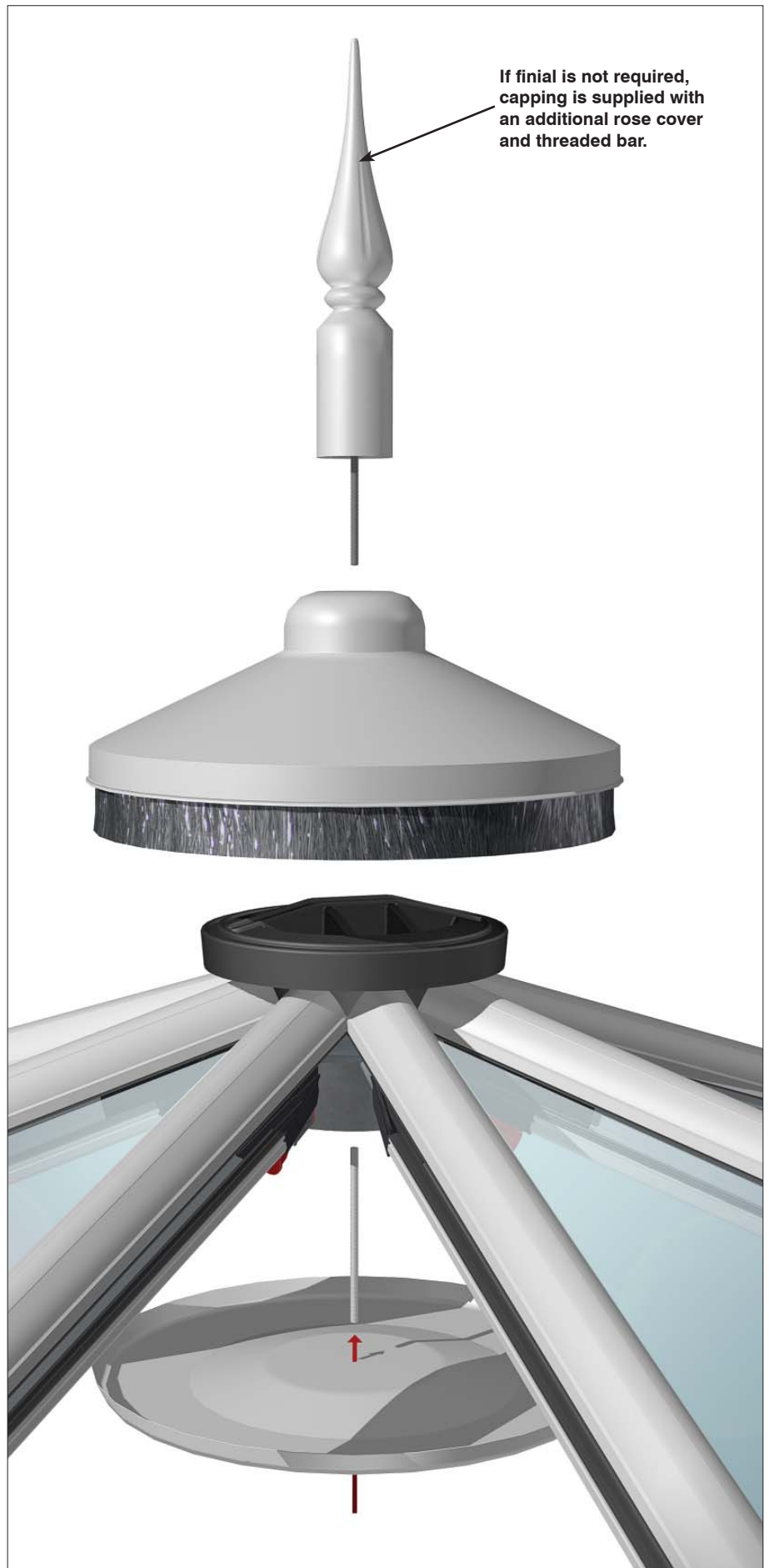



Layout the pieces of the lantern eaves beam.

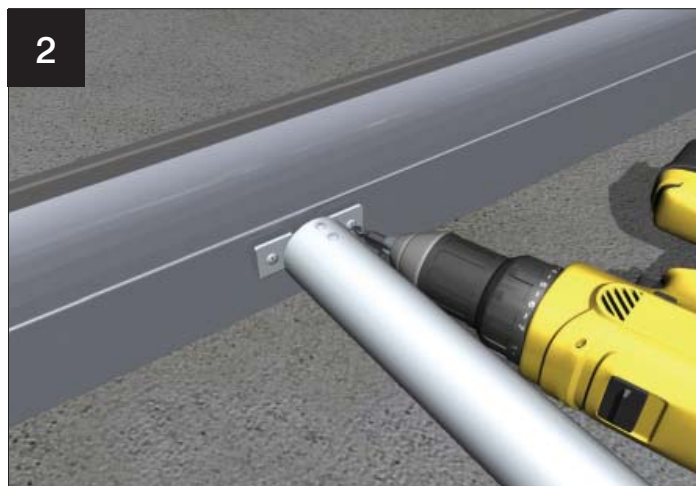

Attach the strut at the mid point of the long sides.



Slide the cleated corners into the adjacent piece of lantern beam



Fasten both fixings in both cleats on every corner



If supplied, fasten to each corner the tie bar drop rod fixing bracket to the underside of the lantern eaves beam.



Now the Lantern eaves beam is assembled into a one piece structure, temporarily support it. Attach the glazing bars according to the component location plan. Tighten the bars, at the pagoda beam end first and then at the main eaves beam second.



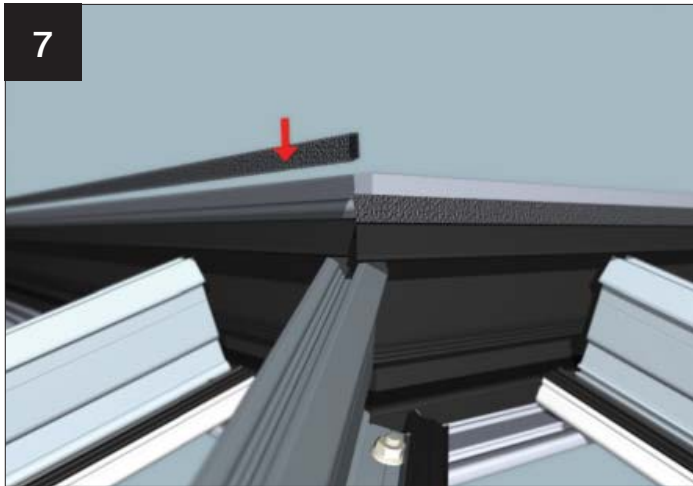

7 Attach the foam gasket into position by peeling off the adhesive protective strip.

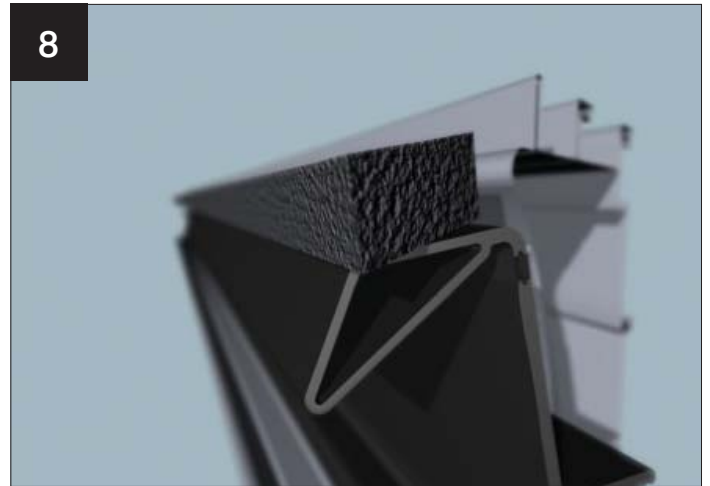

8 This is how it should look.

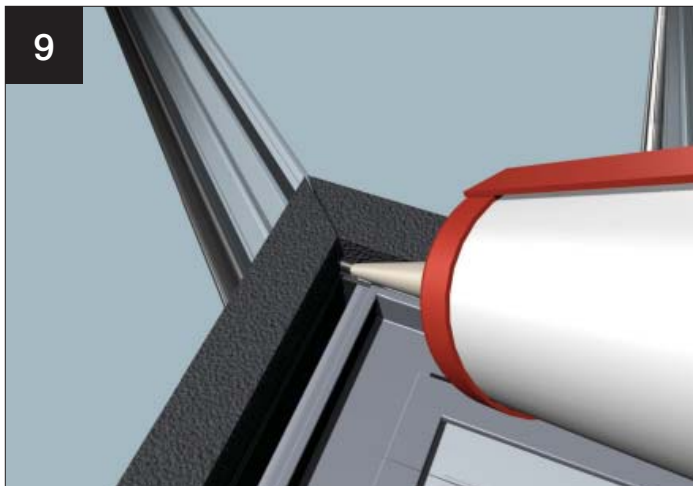

9 At the corners, seal using a sealant appropriate to the glazing material.

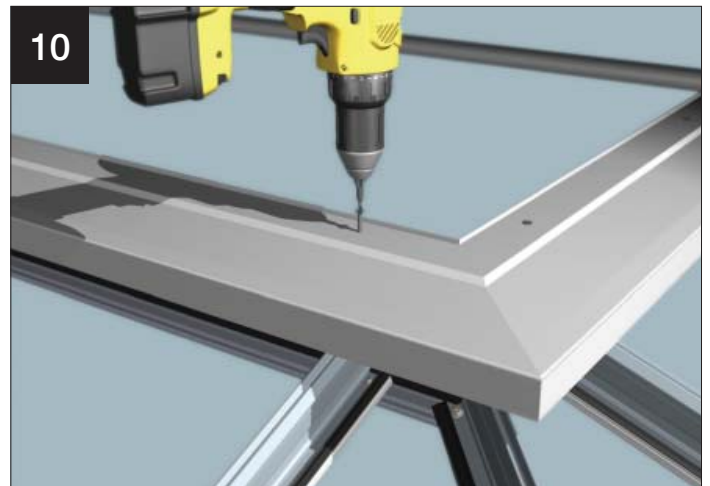

10 For the lantern application, attach the pvc window cill to the beam. Assemble side frames on to pvc cill and build the lantern roof as per section 5 of this guide.

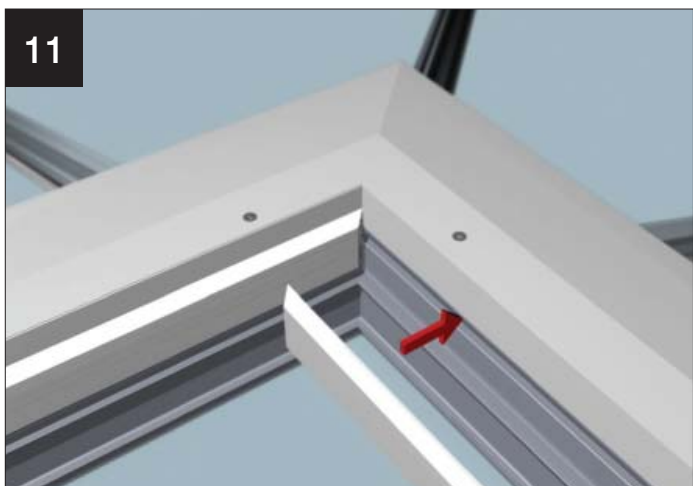

11 Clad off the inside of the upper leg of the aluminium beam.

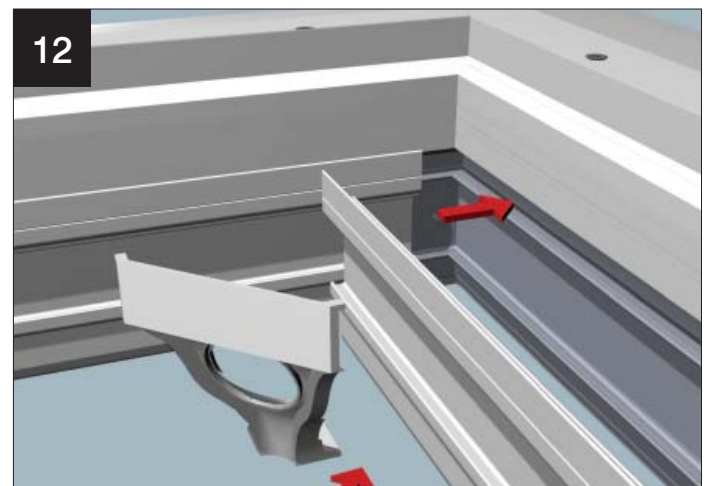

12 Now attach the pvc eaves beam cladding - complete the remainder of the internal claddings.

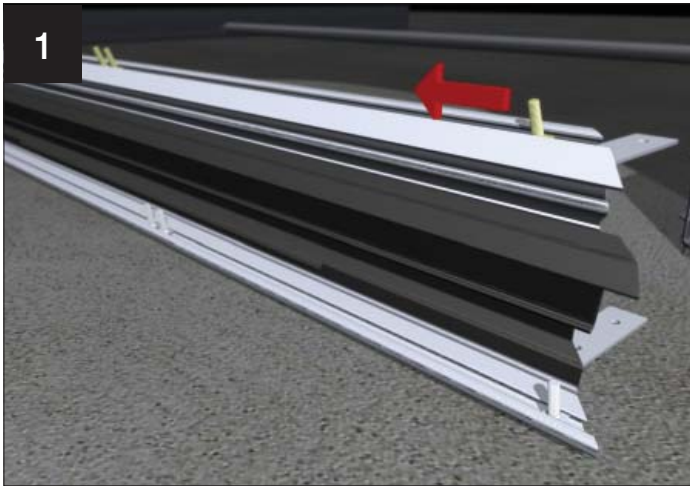

Ensure roofing bolts are threaded into the pagoda eaves beam.

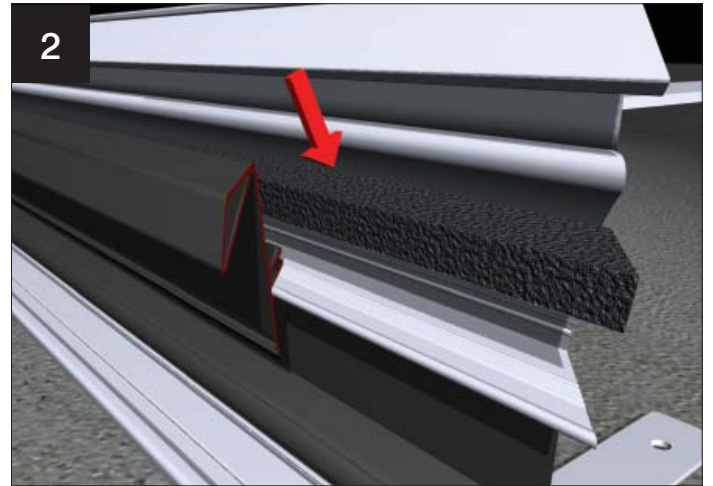

Attach the foam gasket into position by peeling off the adhesive protective strip.



Layout the pieces of the lantern eaves beam.

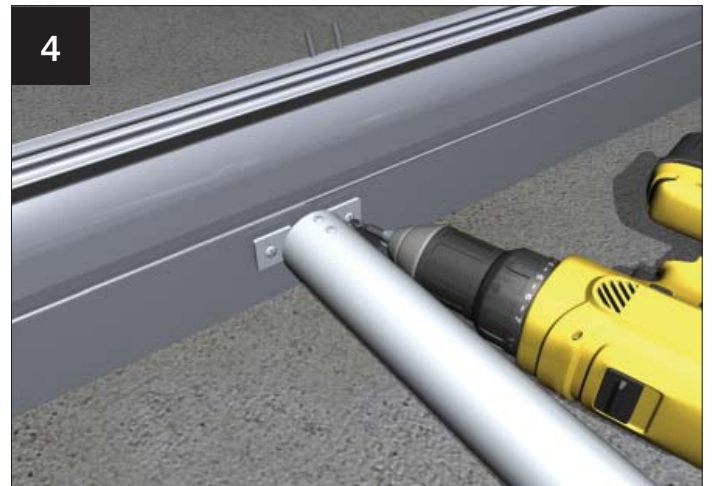

Attach the strut at the mid point of the long sides.



Slide the cleated corners into the adjacent piece of pagoda beam



Fasten both fittings in both cleats on every corner.





7  
If supplied, fasten to each corner the tie bar drop rod fixing bracket to the underside of the pagoda eaves beam.



8  
Now the Pagoda eaves beam is assembled into a one piece structure, temporarily support it. Attach the glazing bars according to the component location plan. Tighten the bars, at the pagoda beam end first and then at the main eaves beam second. At the corners, seal using a sealant appropriate to the glazing material (shown above).



9  
Using the roof location plan, build the upper roof as per section 5 of this guide

**When a pagoda roof hips back to a box gutter against a house wall, it is necessary to install the sealed units in the lower roof prior to assembling the upper roof.**



10  
Glaze the lower pagoda roof fully.





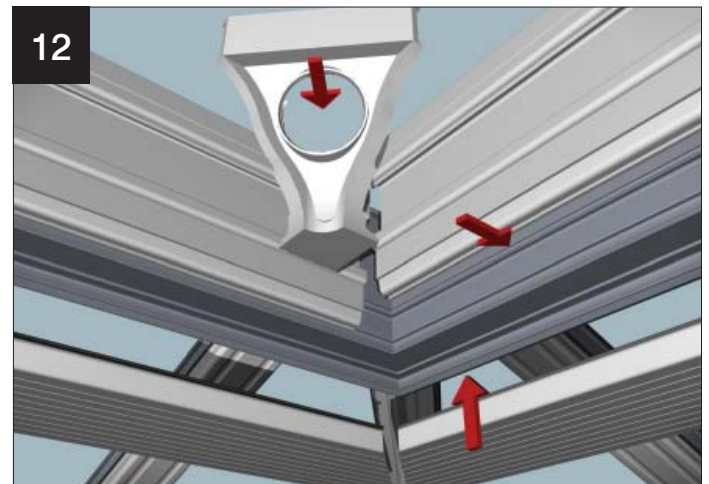





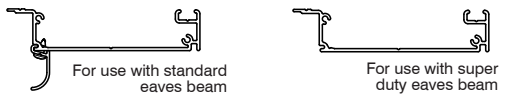

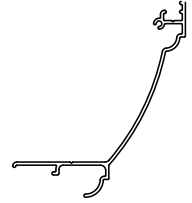
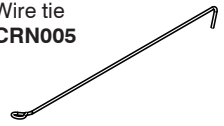
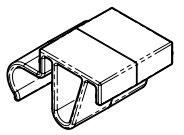
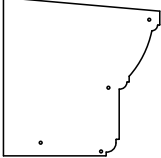



11  
Glaze the upper pagoda roof, and complete all external works



12  
Internally, attach the pvc cladding to the face and underside of the lantern beam.

**Recommended tools** - Long reach magnetic bit, 73mm hole saw. **Additional materials** - Timber baton (treated) 49mm x 20mm and cut to length as required - only used when a gutter return and the host wall is required.

<p>Lower Cornice section CRN __/1</p> <p>SCN __</p>  <p>For use with standard eaves beam</p> <p>For use with super duty eaves beam</p>	<p>Middle Cornice section CRN __/2</p> 	<p>Upper Cornice section CRN __/3</p> 	<p>Wire tie CRN005</p> 				
<p>Support bracket CRN002</p> 	<p>Lean-to / Gable end plate CRN003</p> <p>This item is powder coated both sides to avoid 'handing' issues</p> 	<p>Fixings (supplied in labelled packs)</p> <table border="0"> <tr> <td data-bbox="694 683 805 795"> <p>CRN006 Cleat screw</p>  </td> <td data-bbox="901 683 1045 806"> <p>CRN007 Section screw</p>  </td> <td data-bbox="1141 683 1292 795"> <p>CRN008 End plate screw</p>  </td> <td data-bbox="1348 683 1500 851"> <p>CRN010 Tie wire screw</p>  </td> </tr> </table>		<p>CRN006 Cleat screw</p> 	<p>CRN007 Section screw</p> 	<p>CRN008 End plate screw</p> 	<p>CRN010 Tie wire screw</p> 
<p>CRN006 Cleat screw</p> 	<p>CRN007 Section screw</p> 	<p>CRN008 End plate screw</p> 	<p>CRN010 Tie wire screw</p> 				

## CORNICE PRE INSTALLATION INFORMATION

**FILM** - Peel back the protective film at each of the mitred corners, prior to fitting. Ensure all film is removed following installation. Failure to do so will damage the finish over time.

**SEALING** - After installation, do not seal around the down pipe hole (step 1). The gap will allow water to escape from Cornice in the event of extreme weather conditions.

**LADDERS** - Take care when using ladders as they could damage the Cornice gutter.

**PLEASE PASS THIS INFORMATION ON TO THE HOMEOWNER**

### FITTERS TIPS

1. Start the installation of Cornice when the basic roof structure is in place (bars and ridge) but before the glazing and guttering have been installed.
2. Prior to installation please ensure the eaves beam joints are tight. Any gaps could translate through to the Cornice mitres.
3. Try temporarily fixing the lower Cornice sections, position appropriately to obtain the best mitre fit. Remember the lower Cornice section is the datum!
4. Do not force the cleats during assembly. Cleats are used to position the mitre joints only!

## CORNICE INSTALLATION

Ensure the eaves beam, glazing bars, ridge/wallplate are already installed

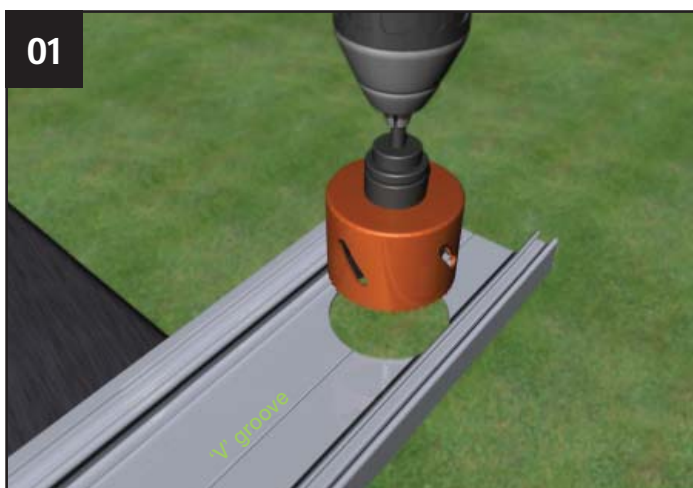

Decide the position of the gutter outlet by lining the extrusion 'v' groove up with the centre of the hole for the down pipe. Using a 73mm dia hole saw, cut the hole for the down pipe in the lower section.

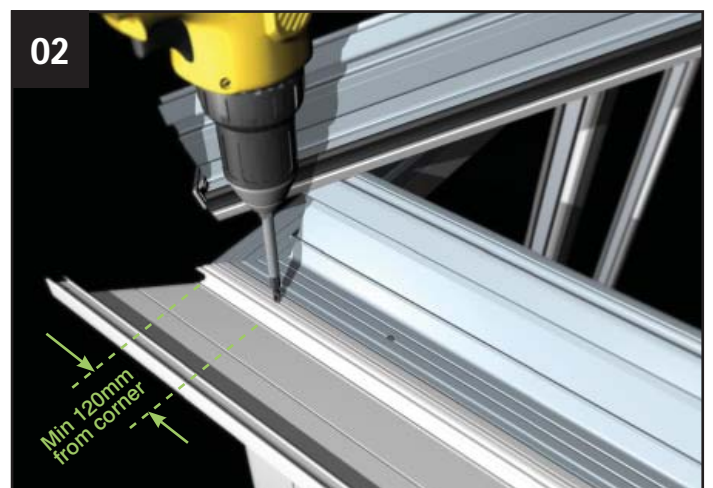

Remove the under gutter trim and dispose of it. Prior to fitting gutter offer up the lower Cornice section then secure into position using the fixings provided (CRN007). **Please note: Always start with the front facet!**



## CORNICE INSTALLATION



Fit the cleats (CRN001) to the desired side using the fixings provided (CRN006) as shown and assemble the remaining lower sections



Secure each corner using the cleats (CRN001) and fixings provided (CRN006).

The gutter and glazing should now be fitted (see main guide). Check integrity of all gutter joints before proceeding further.

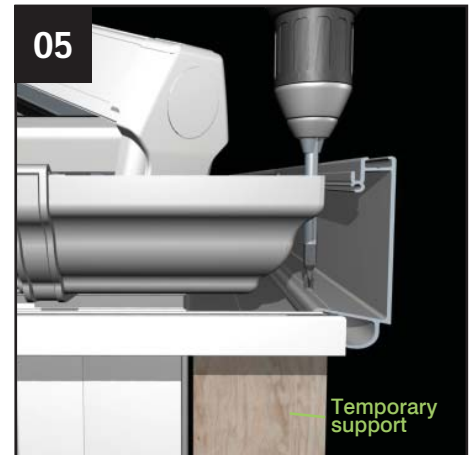

Offer up the middle Cornice section into position, (it may be advisable to temporarily support the lower Cornice section whilst fixing) secure using fixings provided (CRN007). (Long reach driver required).

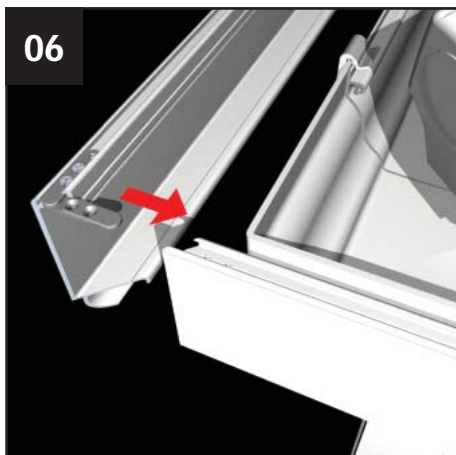

Fit cleats as shown in step 3. Offer up the next middle Cornice section. Continue to support lower section as shown in step 5.

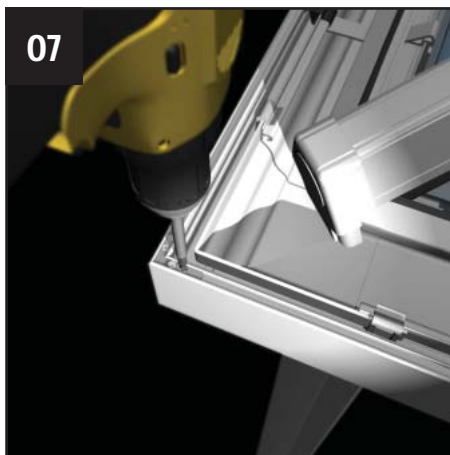

As shown in step 5 it may be advisable to temporarily support the Cornice whilst fixing. Secure corners using the cleats (CRN001) and fixings provided (CRN006).

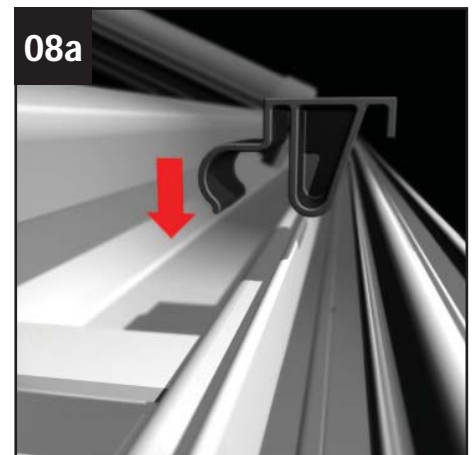

Clip fit the support brackets (CRN002), adjacent to every gutter bracket.



Clip in position.



Temporarily support and fit the upper Cornice section, using the fixings provided (CRN007). Secure the corners using the cleat (CRN001) and fixings (CRN006) as shown in step 3.

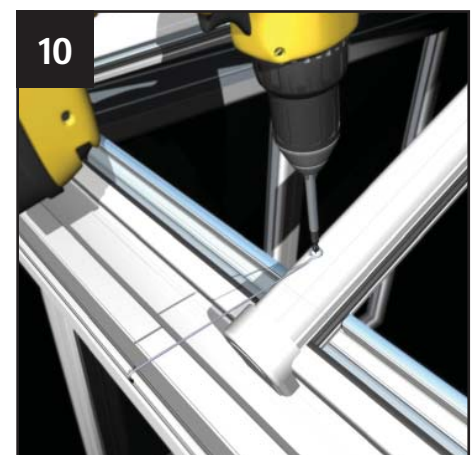

Secure the upper Cornice section using the wire ties at each glazing bar. Hook the wire tie into the pre-drilled hole in the upper Cornice section and screw fix into the glazing bar, ensuring the upper section remains parallel to the frames/roof line.

## CORNICE CORNER JOINTER INSTALLATION

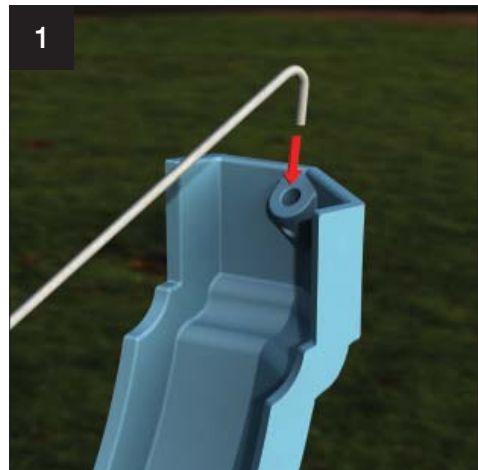
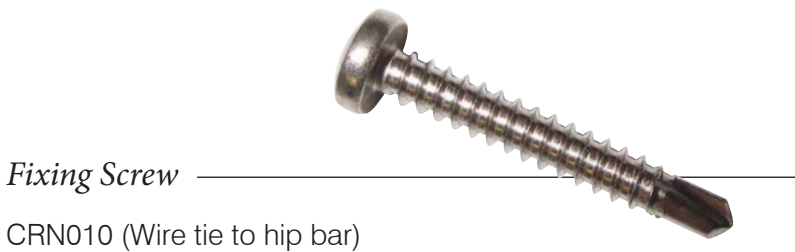
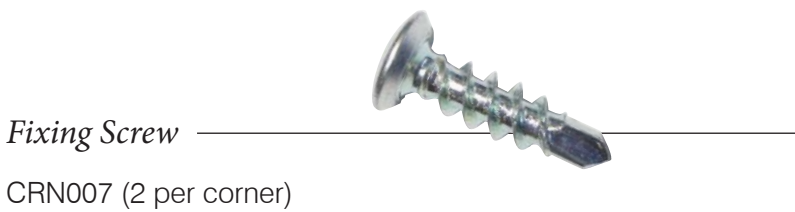
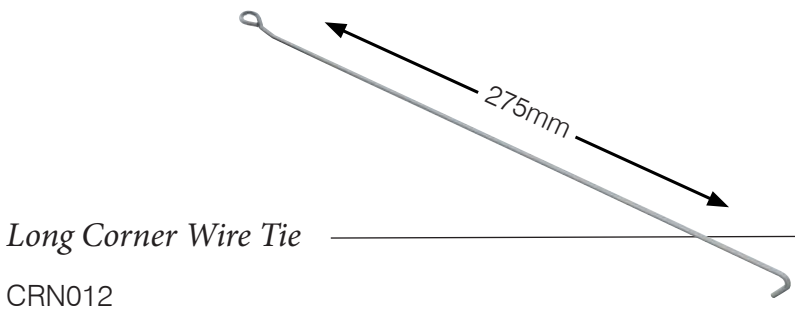
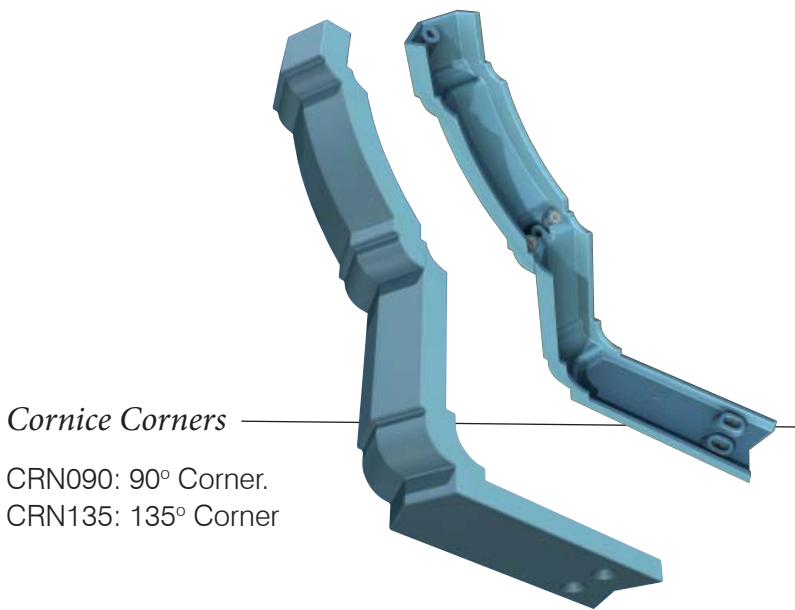

1. Prior to fitting the corner insert the special longer wire tie CRN012, into the corner as indicated



2. Whilst ensuring that the corner remains located in position, screw fix using self drilling screws CRN007

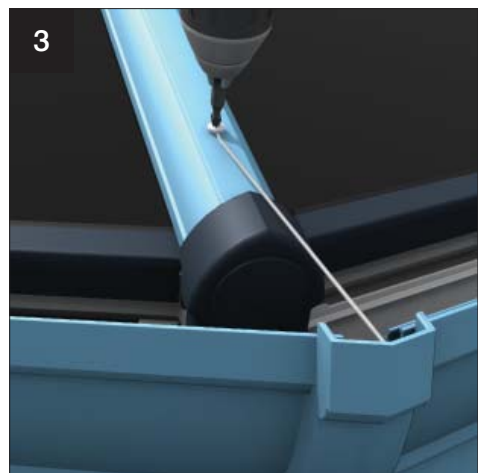

3. Finally secure the corner by screw fixing the wire tie to the glazing bar using self drilling screw CRN010

Please note that it is not compulsory to fit the corners. If a crisp sharp mitre is required the corners need not be fitted, provided due care has been taken during installation. If on the other hand the 'look' of the cast corner is preferred follow the instructions above for each relevant corner. Corners will be supplied for the 135° & 90° external corners.



# CORNICE STRAIGHT JOINTER INSTALLATION

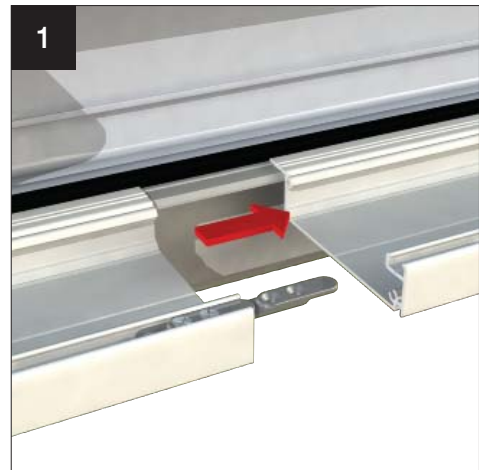
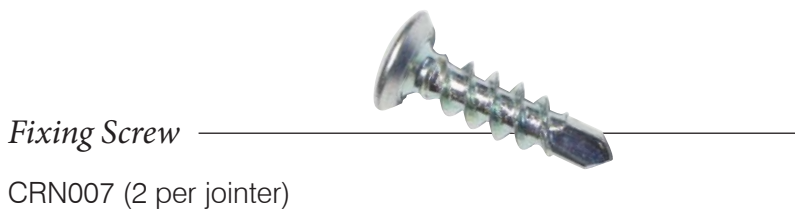
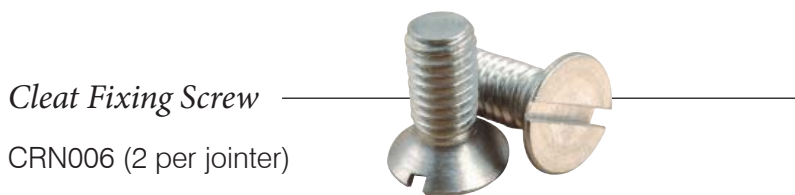
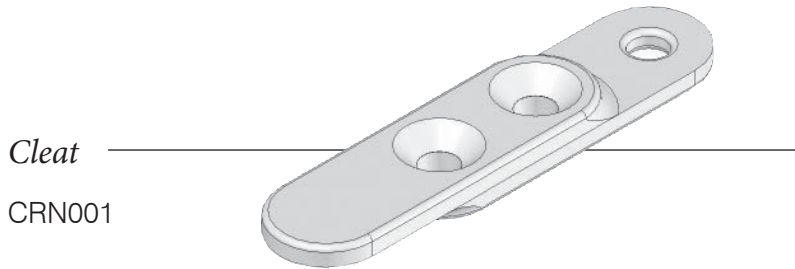
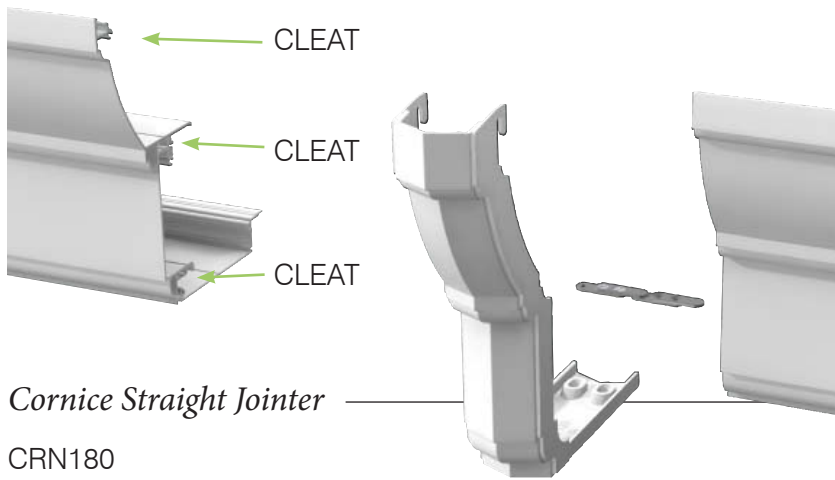

1. Attach the cleat CRN001 using 2 x CRN006 provided, on each side of the joint. Repeat for each of the Cornice 'layers'.

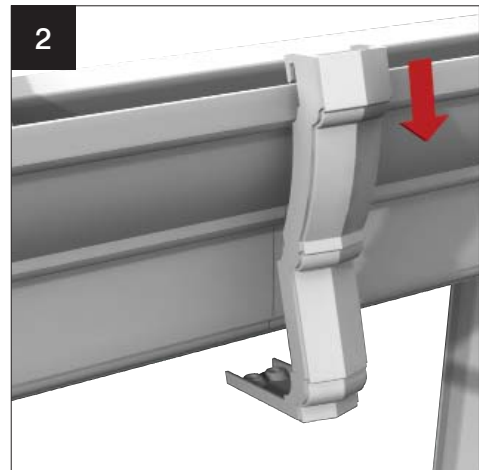

2. Offer up the CRN180 straight jointer, hook over the front lip of the Cornice



3. Whilst ensuring that the corner remains located in position, screw fix using self drilling screws CRN007

Please note that it is not compulsory to fit the jointers provided. If due care has been taken with the installation of the Cornice. If on the other hand the 'look' of the cast jointer is preferred follow the instructions above for each relevant jointer. Some companies MAY have ordered a 'dummy' joint at 'mid-run', if so just follow steps 2 + 3 . The die cast straight jointer can also be configured on site to be used at host wall position.

## CORNICE INSTALLATION - ADDITIONAL DETAILS

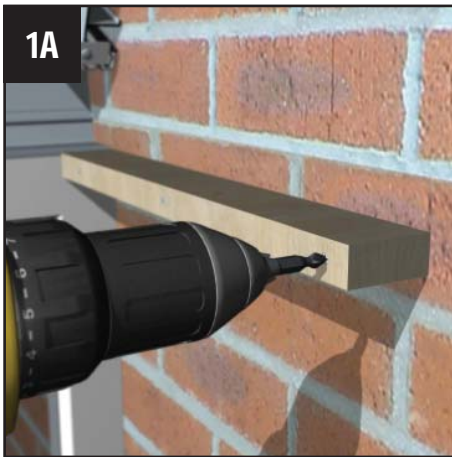

**1A**  
**Gutter return detail** - If the gutter returns along the host wall (shown below) complete steps A and B after step 4 of the main installation.

Ensure the treated timber baton (49mm x 20mm) is level, then fix into position.

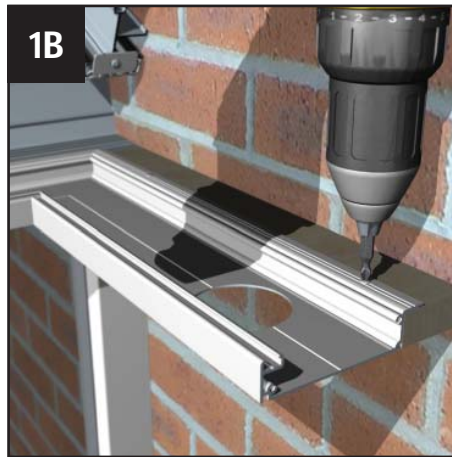

**1B**  
 Secure lower section using fixings provided (CRN007)

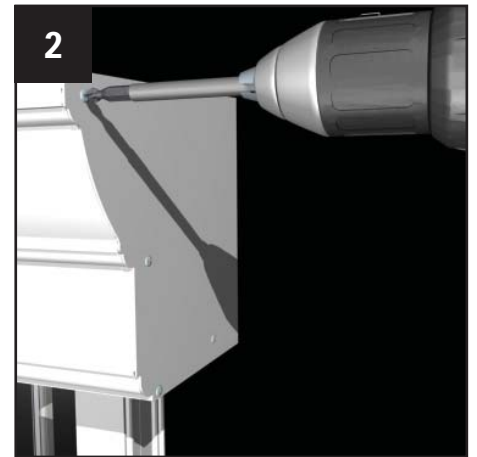

**2**  
**Gutter stop end detail** - Used with lean-to roofs, gable roofs or when the gutter returns along the host wall. Secure the end plate into position using the fixings provided (CRN008).

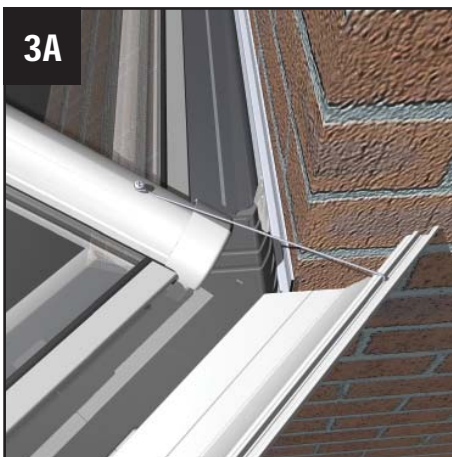

**3A**  
**Cornice & victorian boxgutter detail** - For situations other than that shown, Cornice should be prepped by you on site to suit the wall condition you find.

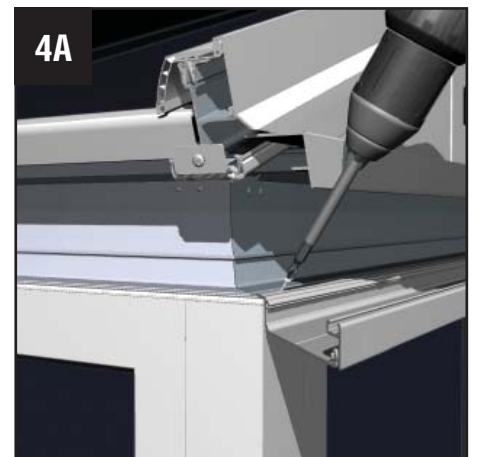

**4A**  
**Cornice & gable eaves beam detail** - Used on lean-to styles with raked frames or duo-pitch gables that use the gable support beam. Fix lower section as shown - continue with the remainder

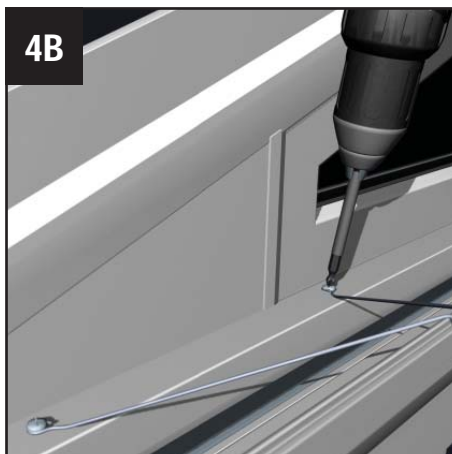

**4B**  
 Fix wire ties at an angle as shown, ensure the Cornice is parallel to the frames/roof line.

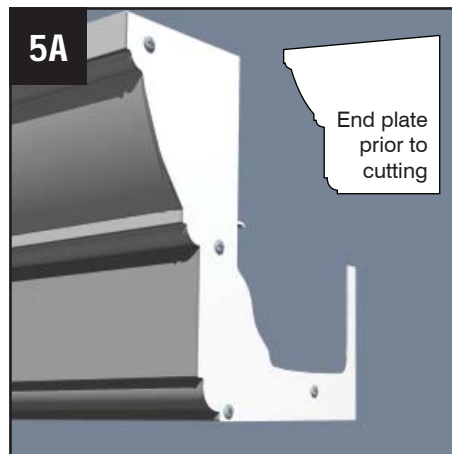

**5A**  
**Cornice & fly through gutter detail** - Used when the gutter extends beyond the Cornice. Take the end plate (CRN003) and cut to the shape of the gutter that projects beyond the Cornice.

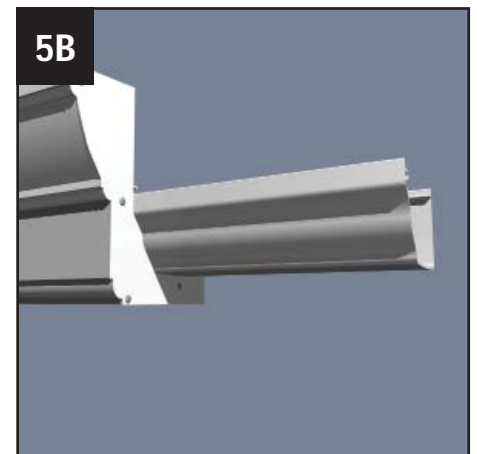

**5B**  
 Typical finished detail.



## CORNICE INSTALLATION - INLINE OUTLET COVER

IT IS IMPORTANT TO CONSIDER THE OUTLET POSITION PRIOR TO FITTING THE CORNICE.  
WHEN THE OUTLET POSITION HAS BEEN DECIDED NOTCH THE CORNICE LOWER PROFILE AS SHOWN

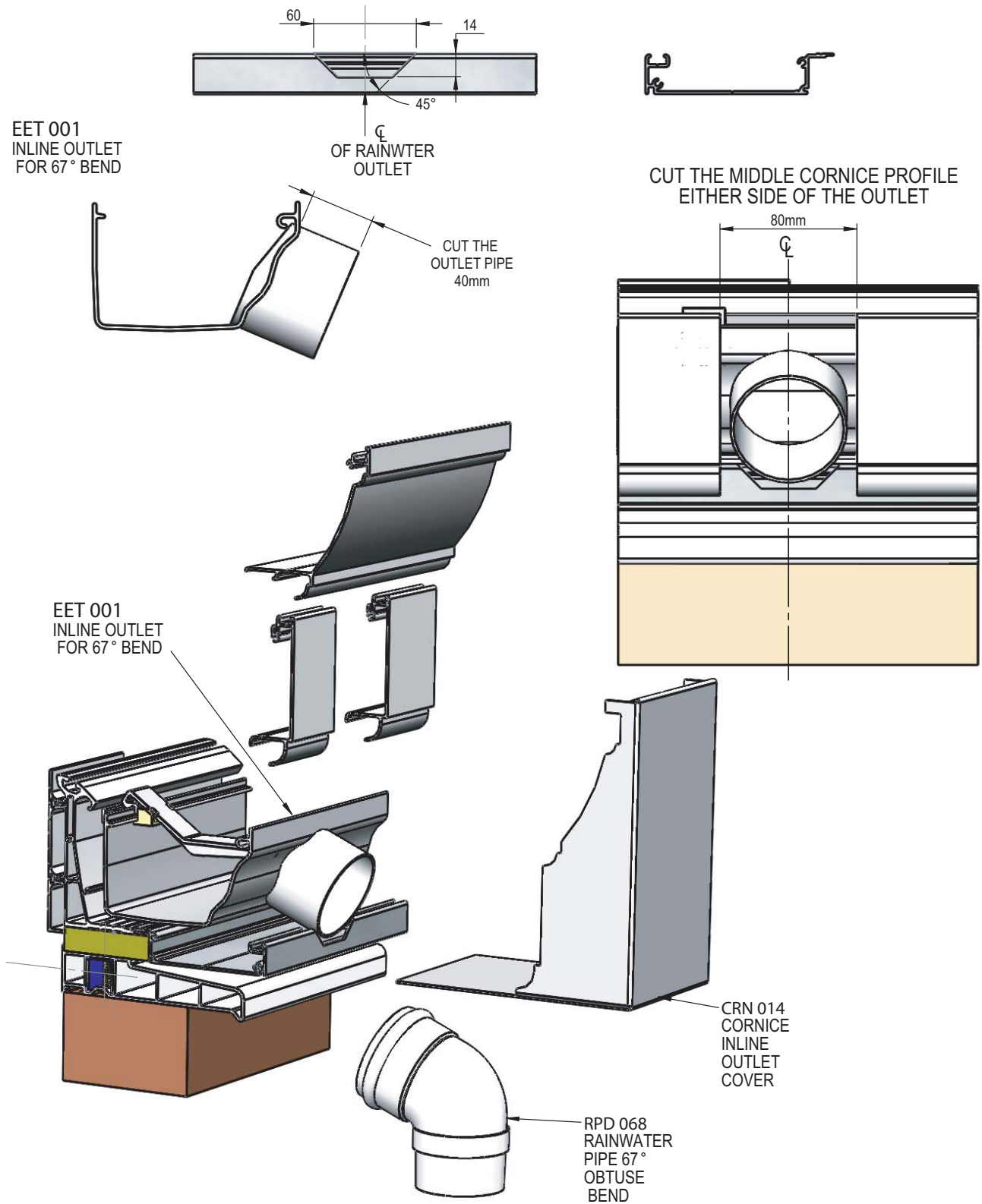

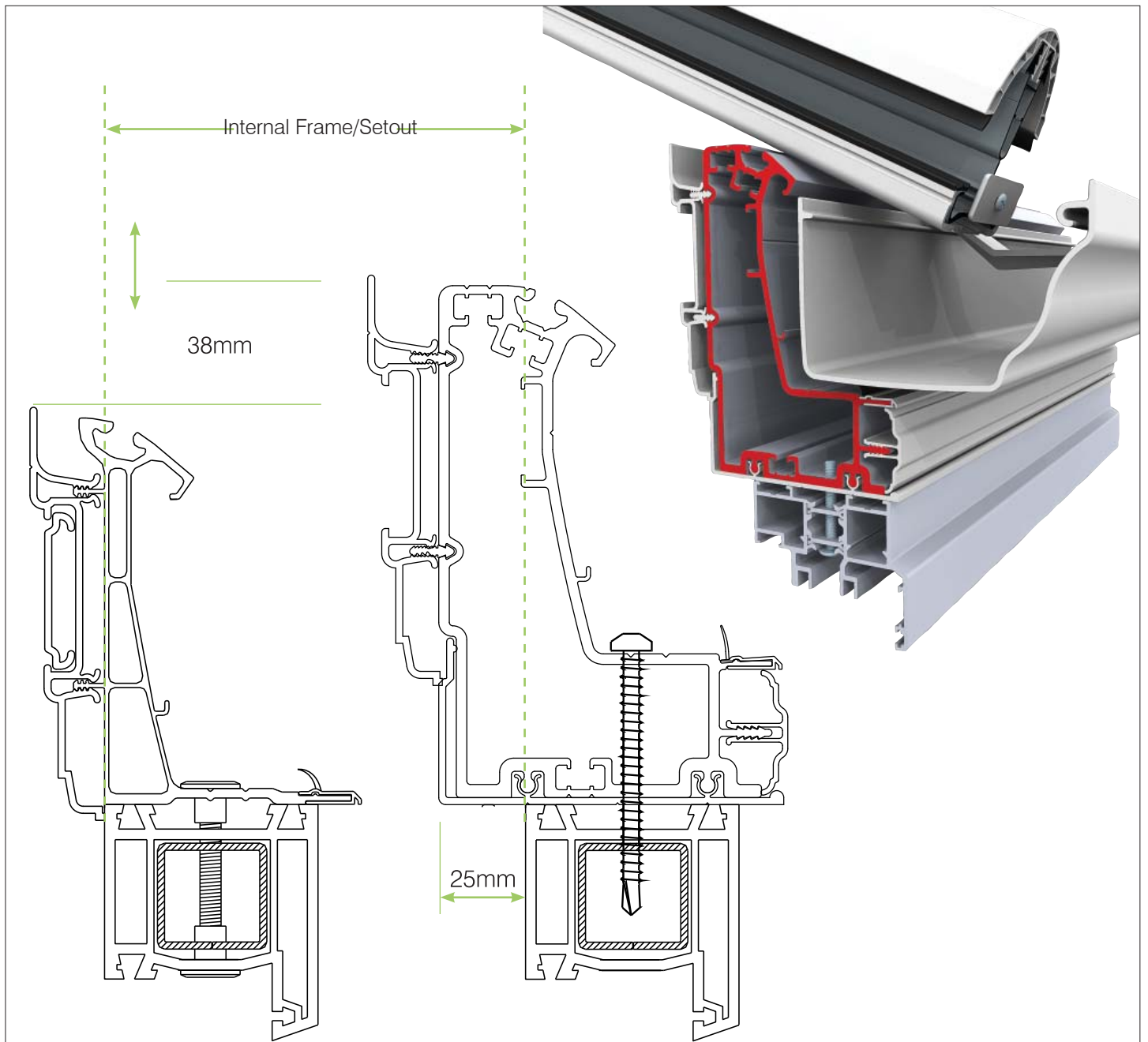

Standard Eaves Beam

Super Duty Eaves Beam

**IMPORTANT NOTE FOR FITTERS**

Super Duty Eaves Beam sits 38mm higher and eaves beam is further 25mm 'in board' of the frames



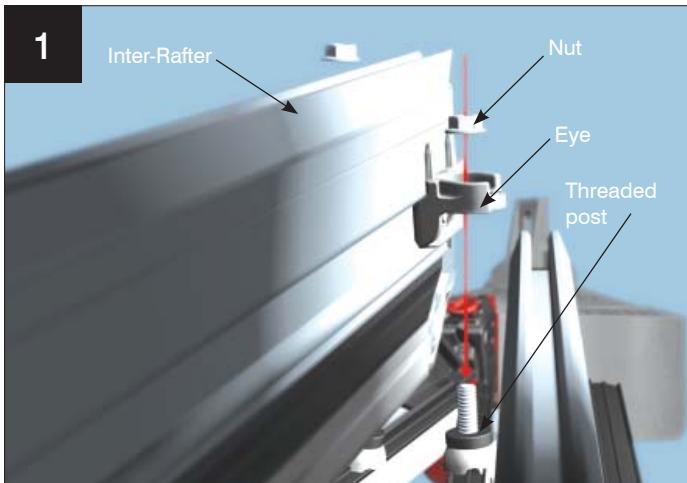

Using the main installation guide, build the roof as normal. Attach the bars to hub end as normal (steps 13-16 installation guide). Insert the Inter-Rafter into its position between the 2 pre-prepared bars and drop the 'eye' over the threaded post.

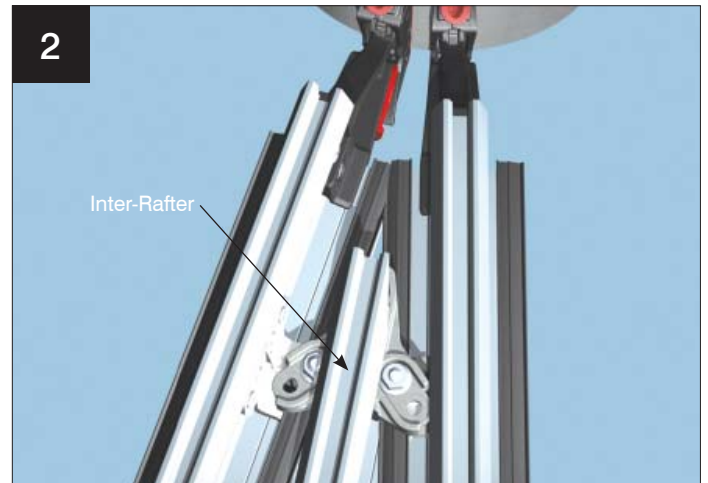

Bolt down using the nuts provided - ensure glazing platforms are level.

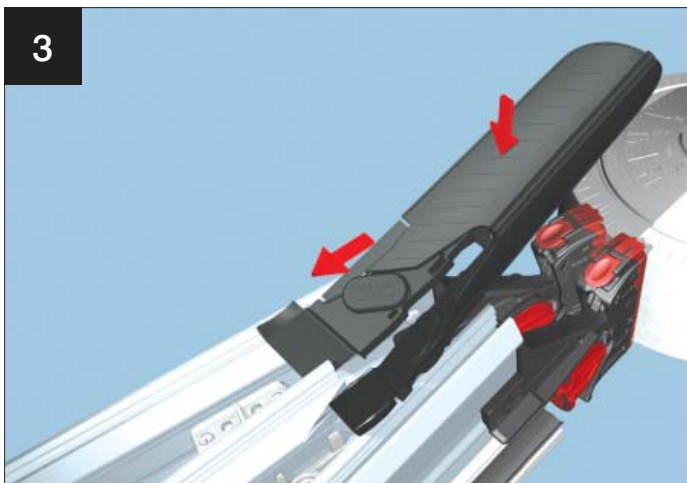

Now attach the Inter-Rafter weathering hood (may require trimming in certain situations).

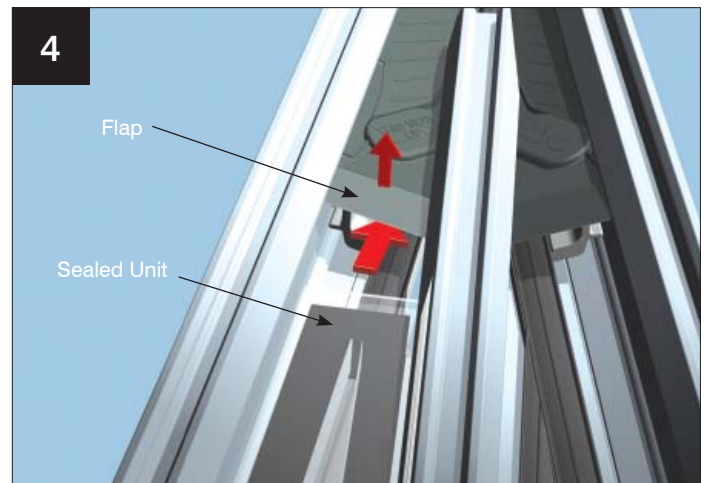

Lift the 'flap' on leading edge of the weathering hood, slide the sealed unit underneath and push flap back into position.

HALF RIDGE TO HALF RIDGE



Take the two pieces of half ridge and offer into final position. Temporary support props are necessary, taking account of appropriate health and safety guidance. Check levels.



Using a spanner or socket, joint the two half ridges together using the nut and bolt provided. Check level and attach to the host wall. Build the remainder of the roof in sequence.

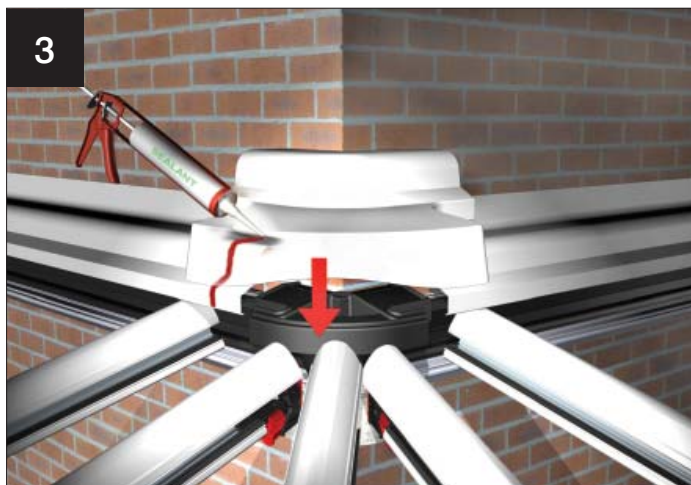

Now, as in section 4, seal around each glazing bar top cap where it meets the inner wall of the 'soft touch' weathering shield. Trial fit the half ridge external radius end top cap into position. Mark and drill for final rivet positions using a 5mm drill bit. Trim to fit (see page 52). When satisfied with fit, apply a bead of appropriate sealant across each end of the half ridge top cap. Place the radius end cover over the weathering shield and rivet into position.

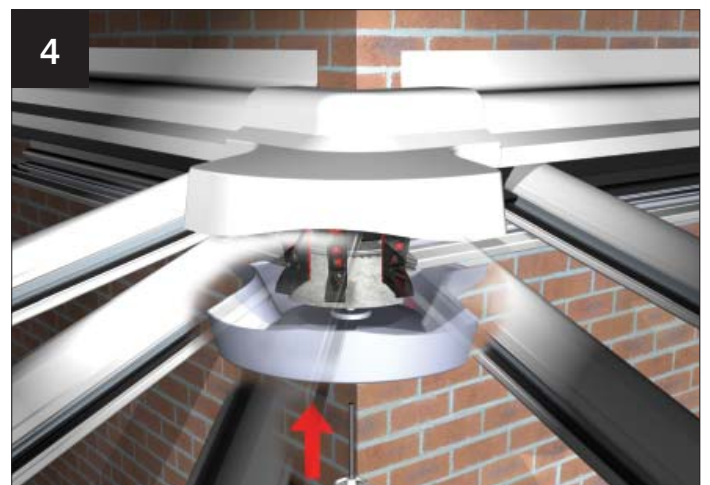

Trial fit the internal radius end cover into position. Minor trimming to ensure a snug fit may be required. Offer into position and secure using the threaded plastic rose.

### FITTERS TIP - Radius end top cap

- Plan for access
- Leave a panel out to enable access for fitting the top cap.
- Temporarily pack the glazing bar top caps as required where panel has been removed



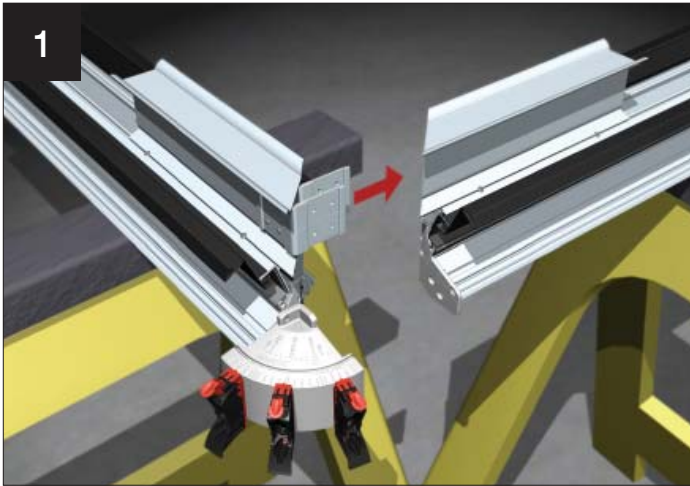

1 Lift separate sections of ridge body on to trestles. Slide twin cleats into position.

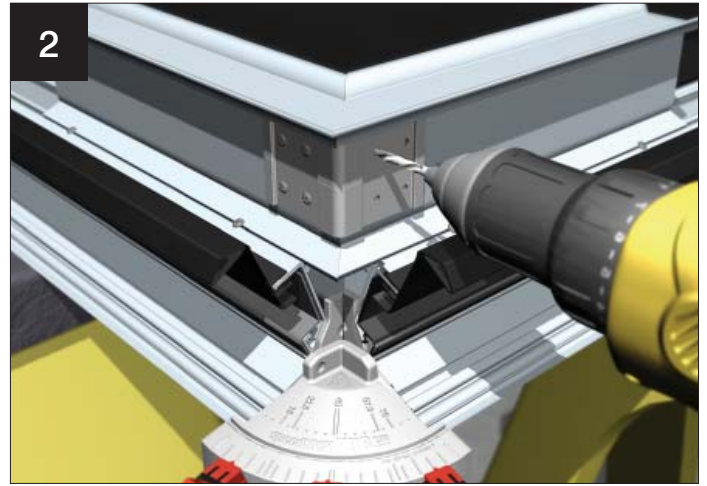

2 In the pre-prepped holes, use the fixings provided to fix the cleats.

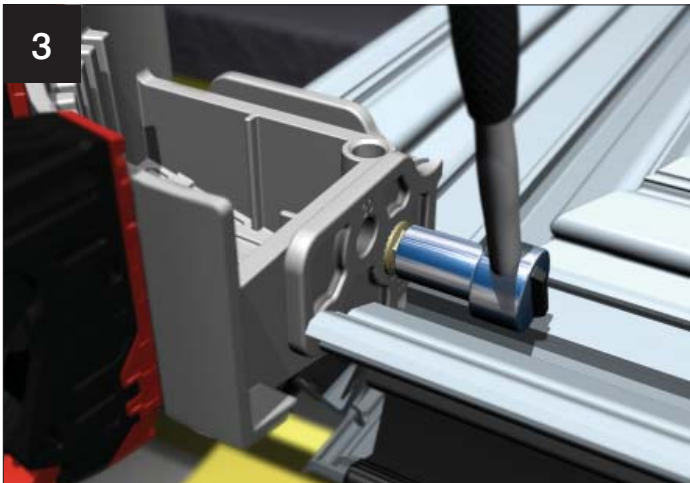

3 Now carefully lift and turn the 'L' shaped ridge on to its back. Using a socket spanner secure the plate on one section of the ridge to the ridge with the hub attached.



4 Temporary support/prop the 'L' shaped ridge. Offer up the hip bars. Secure using steps 13-18 in the main installation guide. Build remainder of the roof as section 4.

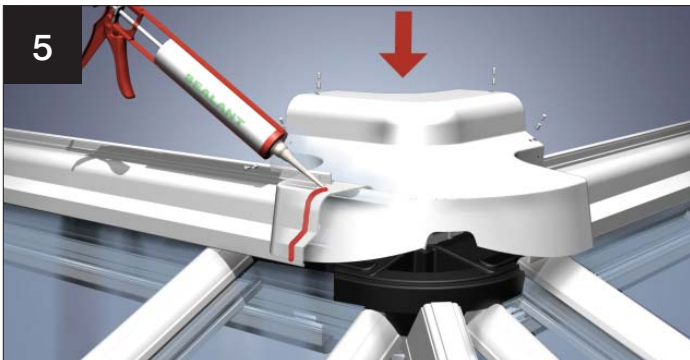

5 Now, as per main guide, seal around each glazing bar top cap where it meets the inner wall of the 'soft touch' weathering shield. Take the length of PVC ridge top cap assemblies, seal the two ends to be joined. Mark and drill for final rivet positions using a 5mm drill bit. Apply plastic rivets. Offer the whole assembly into position, trimming may be required - see over page. The trimming should be in the form of removing a strip across the whole width or as shown above, notching around each bar. Secure ridge into position with 'T' bolts as shown in section 4.

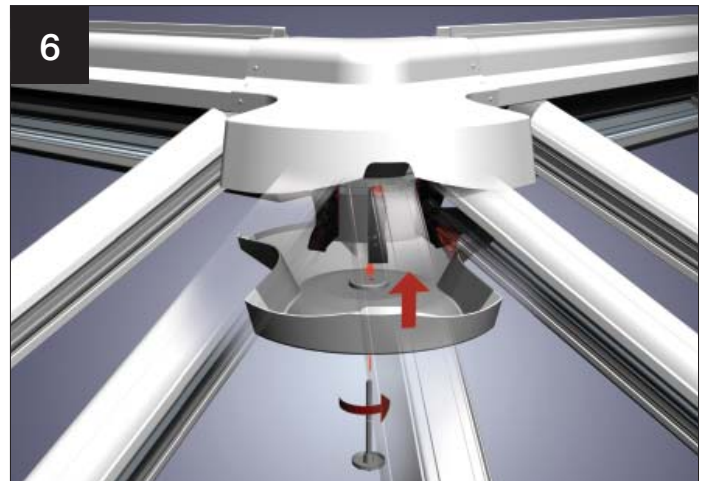

6 Now fit the internal radius end capping using the threaded plastic rose (trimming may be required - see over page).

L SHAPE RIDGES

# Section 23

EXTERNAL

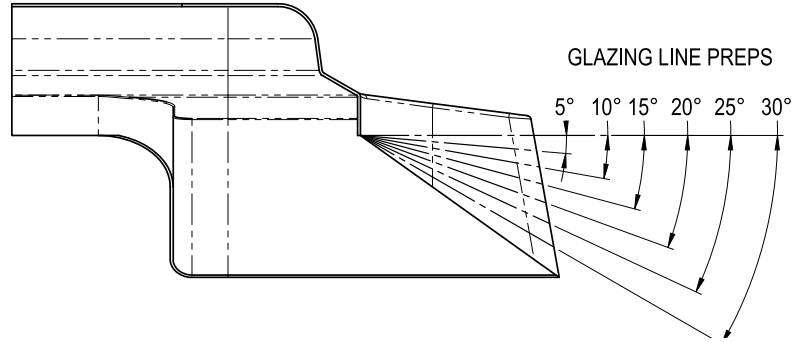
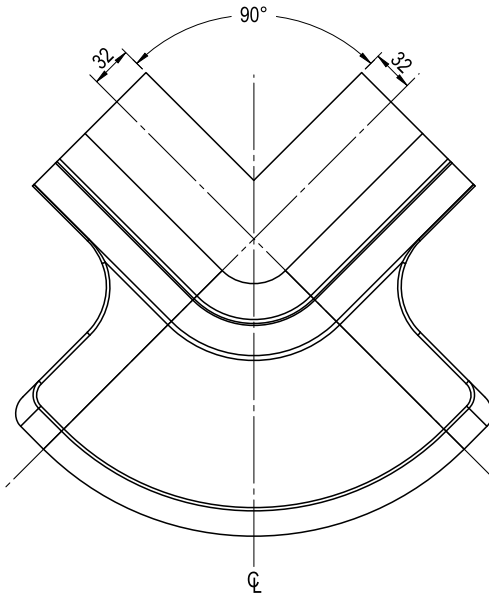

PART IS SYMMETRICAL ABOUT CL

HALF RIDGE UNDERCLADDING PREPS

INTERNAL

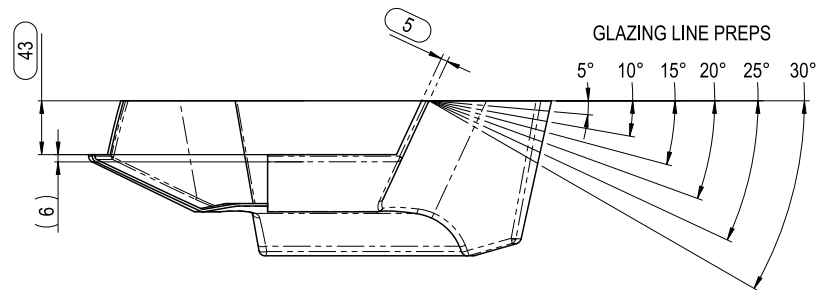
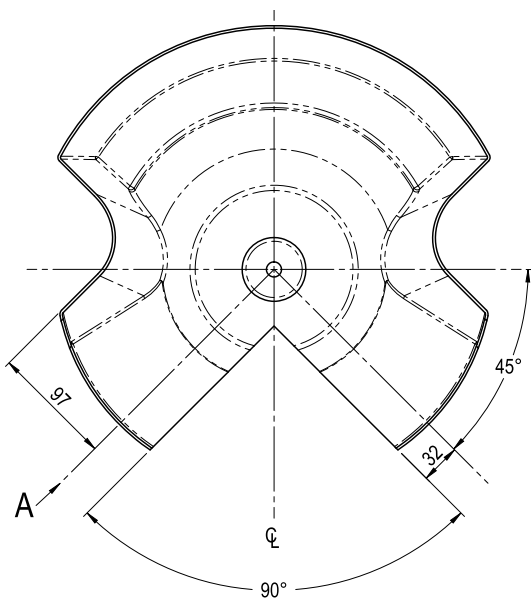

VIEW ON ARROW A

PART IS SYMMETRICAL ABOUT CL



# L SHAPE RIDGES

EXTERNAL

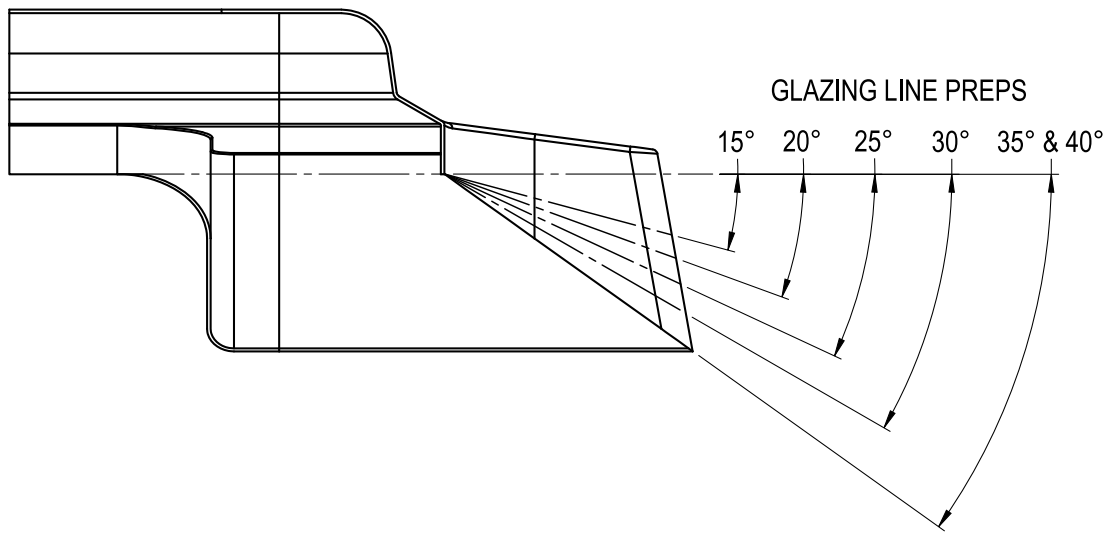

# FULL RIDGE UNDERCLADDING PREPS

INTERNAL

15-30° RIDGES PREP

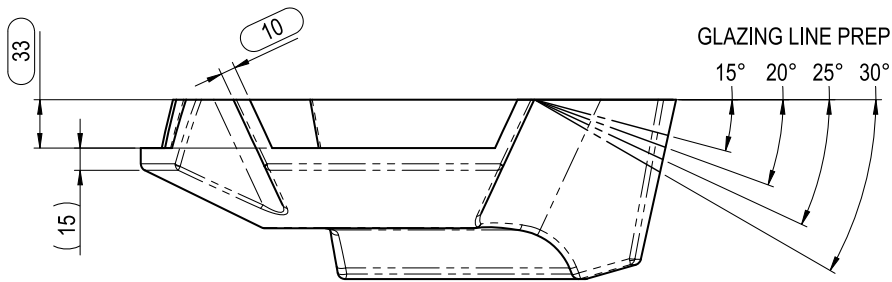

35° RIDGE PREP

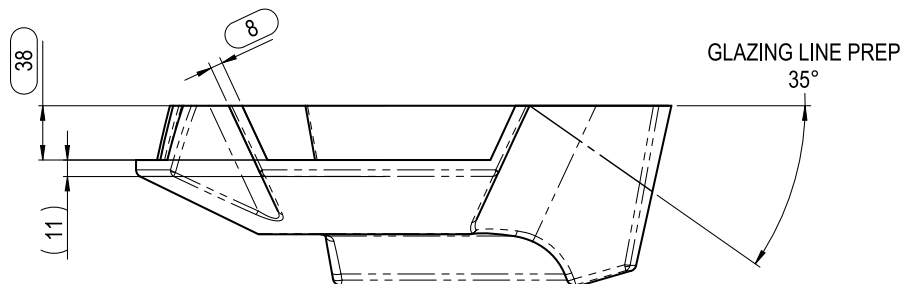

40° RIDGE PREP

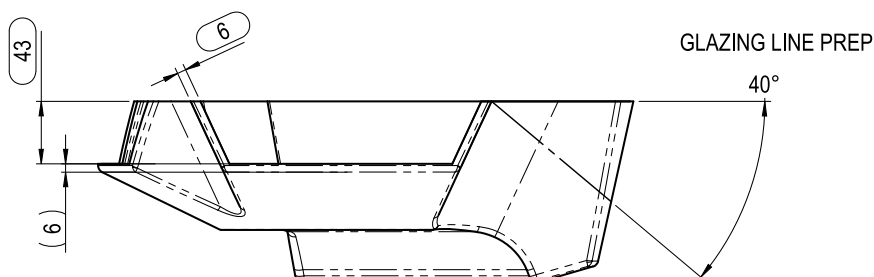

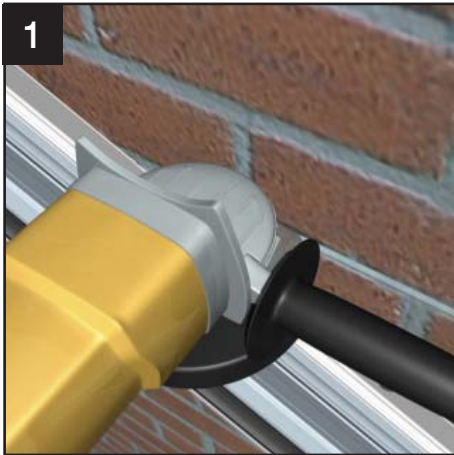

1 Ensure the pre-formed soaker is clipped into the starter bar. At this stage it is easiest to mark and cut out for the lead flashing. For best results always grind a 35mm deep slot to allow Conservaflash to be let into the wall. Brush out any dust from the channel.

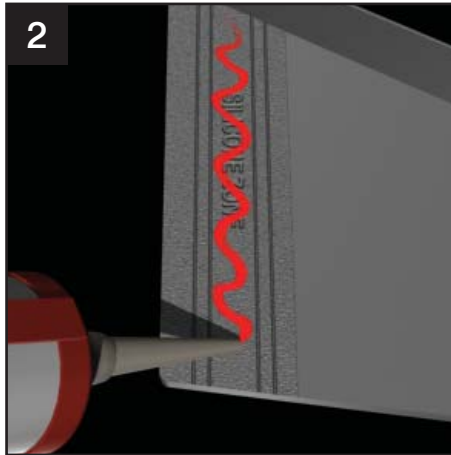

2 Trial fit the stepped flashing. Start installing from the gutter towards the ridge. Apply sealant (clear or grey low modulus neutral cure) along the two internal weather bar grooves.

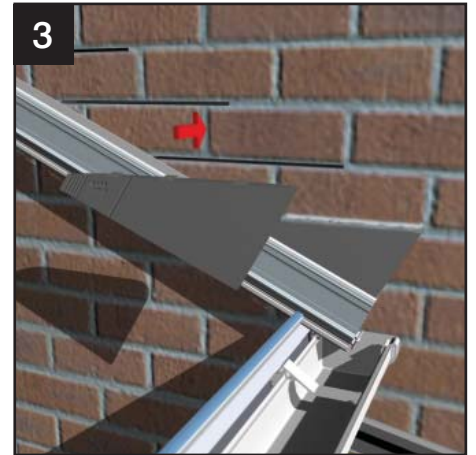

3 Place Conservaflash into the ground out mortar joint at the gutter end, ensuring lower edge locates into the 'J' soaker.

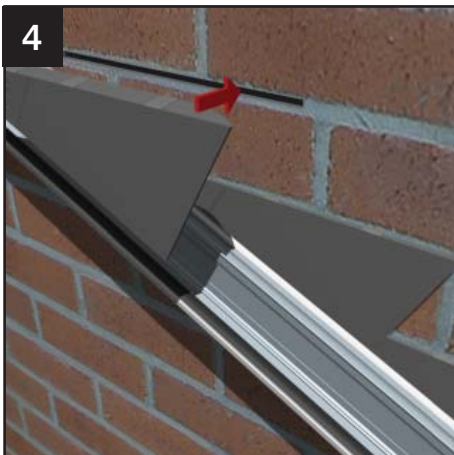

4 The unique integral mechanical retention wedge clips bite into the brickwork ensuring positive location. Insert the next stepped flashing (using sealant on the back), ensuring it overlaps to marked minimum. Continue up the roof, both slopes, with stepped flashings.

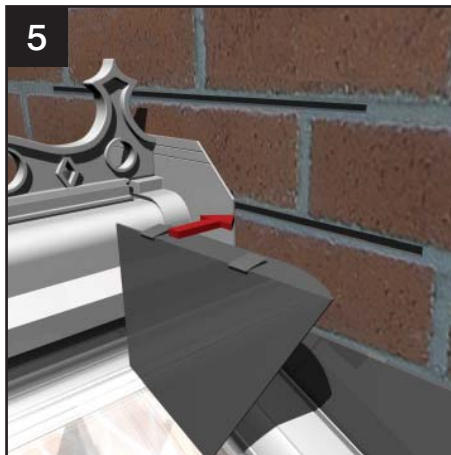

5 Add last couple of stepped flashings to each side of the ridge.

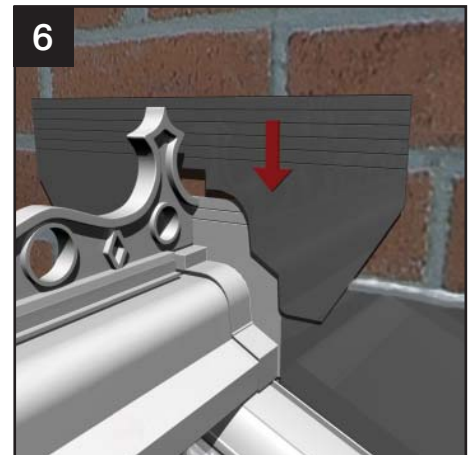

6 'Butter' the reverse side of the saddle trim and place over the ridge body.

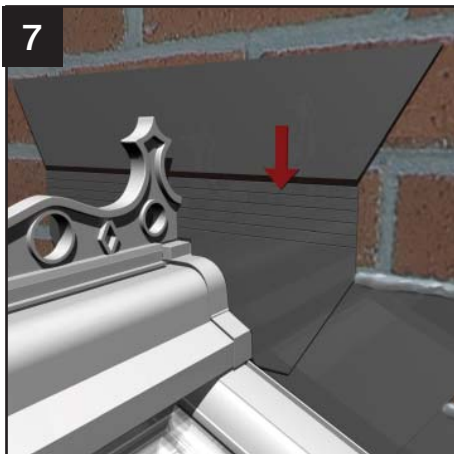

7 Offer up the horizontal flashing which should typically sit two courses above the stepped flashing. Trim the edges off the horizontal flashing to suit the roof pitch.

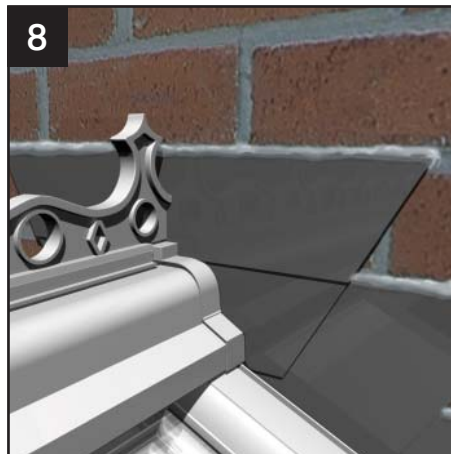

8 Seal the edges of the ridge horizontal flashing, apron edges and the top edge of the stepped flashings. Use either low modulus neutral cure for standard sealed units/poly or MS polymer sealant for self cleaning glass like Conservaglass.



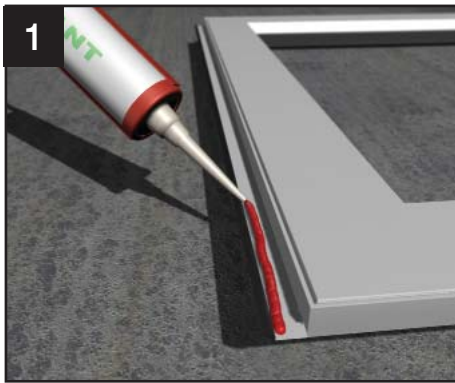

With the opening sash removed, lay the mainframe upside down on a smooth clean surface (protect the surface to prevent damage). Run a continuous bead of sealant (appropriate to the glass type) immediately behind the co-extruded gasket on the upper and lower legs.

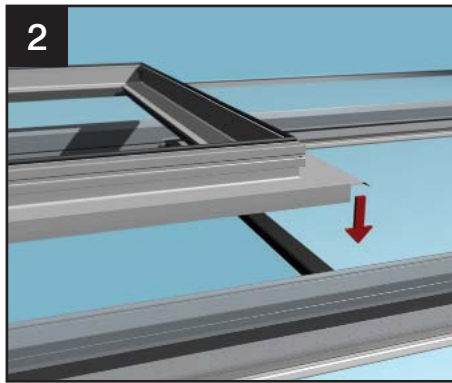

Carefully lower the frame into position on to the upper double glazed unit, making sure that any glazing tape has been removed from the edges of the sealed unit).

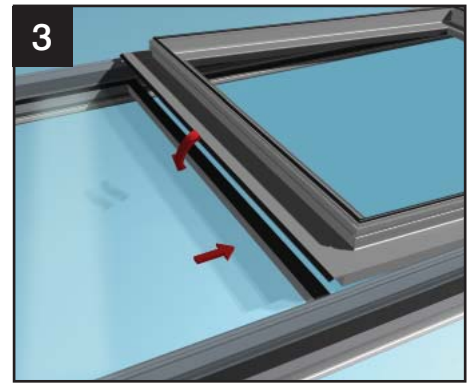

Lift the lower mainframe leg and offer into position the lower double glazed unit. Press down the mainframe firmly into position.

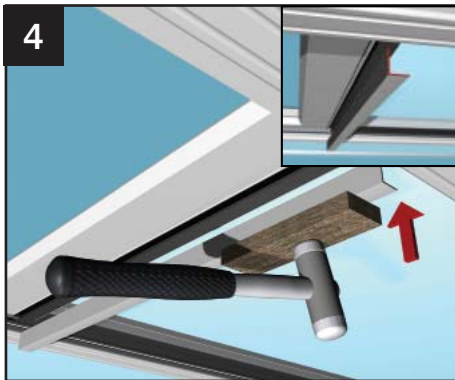

From inside, knock in the 'L' shaped serated glazing beads to the top and bottom edges of the mainframe. NOTE: We recommend a second person to support the mainframe on the outside whilst carrying out this procedure.

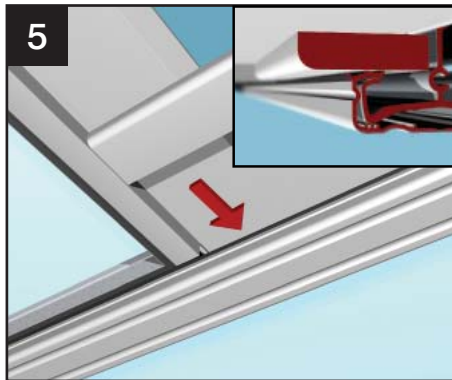

Down each side of the roof vent mainframe an 8mm (or 20mm) thick PVC architrave type packer is provided to suit the glazing thickness. Position as shown above.

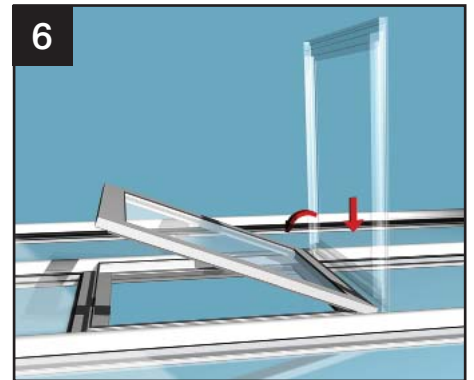

When the sealant on the mainframe has cured, re-fit the outer sash by holding vertically and re-engage on to the 'S' shaped hinge, before lowering into position. Refer to vent installation guide for further information about attaching the opening mechanism etc.

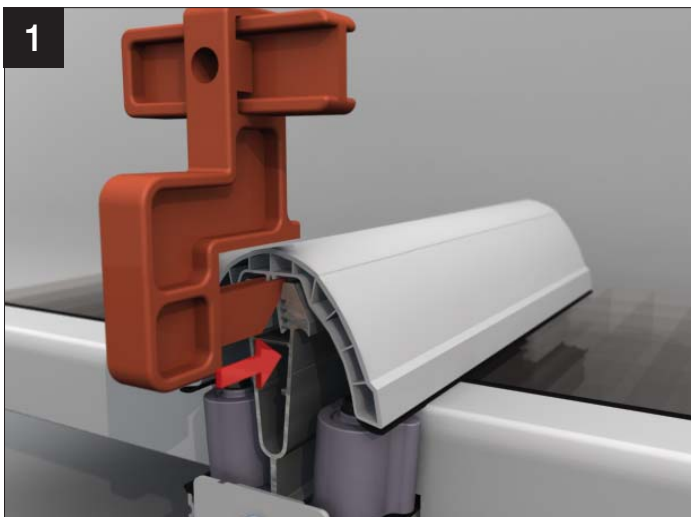

Insert the capping removal tool as shown.

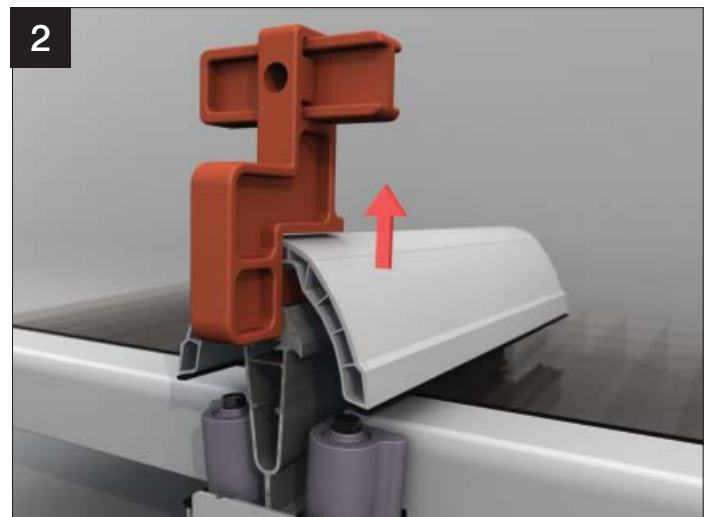

Lift the capping removal tool up, releasing the top cap legs from the aluminium.



**Loggia Prestige**



**Loggia Premium**

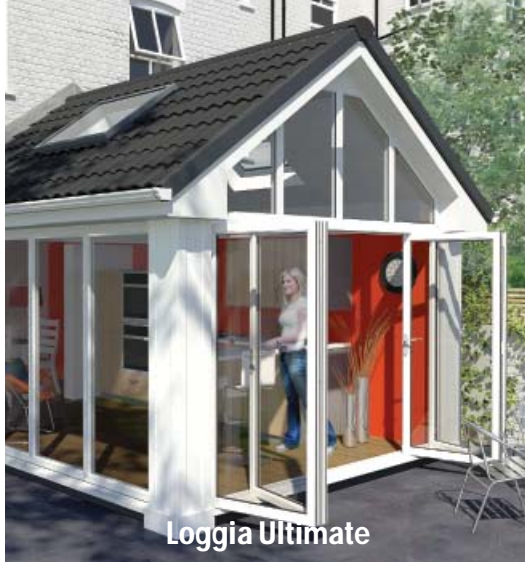

**Loggia Ultimate**

**QUANTAL**

[www.quantal.co.uk](http://www.quantal.co.uk)

**ultraframe**  
Transforming light and space

[www.ultraframe.co.uk](http://www.ultraframe.co.uk)